

**CHAPTER 7.
APPENDICES**

SPECIFICATIONS 7-1
 GENERAL SPECIFICATIONS..... 7-1
 MAINTENANCE SPECIFICATIONS 7-4

GENERAL TORQUE SPECIFICATIONS. 7-17

DEFINITION OF UNITS 7-17

CONVERSION TABLES. 7-18

LUBRICATION DIAGRAM 7-19

CABLE ROUTING 7-23

SRX600S/SC WIRING DIAGRAM

APPENDICES

SPECIFICATIONS
GENERAL SPECIFICATIONS

Model	SRX600S/SC
Model Code Number:	SRX600S: 2EF SRX600SC: 2EG
Vehicle Identification Number:	SRX600S: JYA2EF00 * GA000101 SRX600SC: JYA2EG00 * GA000101
Engine Starting Number:	SRX600S: 2EF-000101 SRX600SC: 2EG-000101
Dimensions:	
Overall Length	2,120 mm (83.5 in)
Overall Width	705 mm (27.8 in)
Overall Height	1,055 mm (41.5 in)
Seat Height	760 mm (29.9 in)
Wheelbase	1,385 mm (54.5 in)
Minimum Ground Clearance	145 mm (5.7 in)
Basic Weight:	
With Oil and Full Fuel Tank	SRX600S: 176 kg (388 lb) SRX600SC: 176.5 kg (389 lb)
Minimum Turning Radius	2,600 mm (102.4 in)
Engine:	
Engine Type	Air cooled 4-stroke, SOHC
Cylinder Arrangement	Single cylinder
Displacement	595 cm ³
Bore x Stroke	95.0 x 84.0 mm (3.740 x 3.307 in)
Compression Ratio	8.5 : 1
Compression Pressure	1,177 kPa (12 kg/cm ² , 171 psi)
Starting System	Kick starter
Lubrication System	Dry sump
Oil Type or Grade:	
Engine Oil	Yamalube 4-cycle oil or SAE 20W40 type SE motor oil
Oil Capacity:	
Engine Oil:	
Periodic Oil Change	2.0 L (1.8 Imp qt, 2.1 US qt)
With Oil Filter Replacement	2.1 L (1.9 Imp qt, 2.2 US qt)
Total Amount	2.4 L (2.1 Imp qt, 2.5 US qt)
Air Filter	Dry type element
Fuel:	
Type	Regular gasoline
Tank Capacity	15.0 L (3.3 Imp gal, 4.0 US gal)
Reserve Amount	3.0 L (0.7 Imp gal, 0.8 US gal)

SPECIFICATIONS

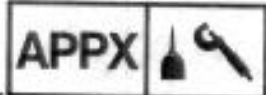



Model	SRX600S/SC	
Carburetor: Type/Manufacturer	Y27PV x 1/TEIKEI KIKAI	
Spark Plug: Type/Manufacturer Gap	DP8EA-9, X24EP-U9/NGK, N.D. 0.8 ~ 0.9 mm (0.031 ~ 0.035 in)	
Clutch Type	Wet, multiple-disc	
Transmission: Primary Reduction System Primary Reduction Ratio Secondary Reduction System Secondary Reduction Ratio Transmission Type Operation Gear Ratio: 1st 2nd 3rd 4th 5th	Gear 74/31 (2.387) Chain 37/15 (2.466) Constant mesh, 5-speed Left foot operation 30/13 (2.307) 27/17 (1.588) 24/20 (1.200) 21/22 (0.954) 21/27 (0.777)	
Chassis: Frame Type Caster Angle Trail	Double cradle 26° 103 mm (4.06 in)	
Tire: Type Size (Front) Size (Rear) Wear Limit	Tubeless 100/80-18 53S BRIDGESTONE YKD 120/80-18 62S BRIDGESTONE KJK 1.0 mm (0.04 in)	
Tire Pressure (Cold Tire): Basic Weight: With Oil and Full Fuel Tank Maximum Load*	SRX600S: 176 kg (388 lb) SRX600SC: 176.5 kg (389 lb) SRX600S: 204 kg (450 lb) SRX600SC: 203.5 kg (449 lb)	
Cold Tire Pressure: Up to 90 kg (198 lb) Load*	FRONT	REAR
90 kg (198 lb)*~ Maximum Load*	177 kPa (1.8 kg/cm ² , 26 psi)	196 kPa (2.0 kg/cm ² , 28 psi)
High Speed Riding	196 kPa (2.0 kg/cm ² , 28 psi)	226 kPa (2.3 kg/cm ² , 32 psi)
	196 kPa (2.0 kg/cm ² , 28 psi)	226 kPa (2.3 kg/cm ² , 32 psi)
	* Load is the total weight of cargo, rider, passenger, and accessories.	



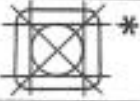

Model	SRX600S/SC
Brake: Front Brake Type Operation Rear Brake Type Operation	Dual disc brake Right hand operation Single disc brake Right foot operation
Suspension: Front Suspension Rear Suspension	Telescopic fork Swingarm
Shock Absorber: Front Shock Absorber Rear Shock Absorber	Coil spring, Oil damper Coil spring, Oil/Gas damper
Wheel Travel: Front Wheel Travel Rear Wheel Travel	140 mm (5.5 in) 100 mm (3.9 in)
Electrical: Ignition System Generator System Battery Type Battery Capacity	CDI AC Magneto generator 12N5-3B 12V, 5AH
Headlight Type	Bulb type (Quartz bulb)
Bulb Wattage/Quantity: Headlight Tail/Brake Light Flasher Light Indicator Light: "NEUTRAL" "HIGH BEAM" "TURN" Meter Light	12V, 60W/55W x 1 12V, 8W/27W x 1 12V, 27W x 4 12V, 3.4W x 1 12V, 3.4W x 1 12V, 3.4W x 1 12V, 3.4W x 2

MAINTENANCE SPECIFICATIONS

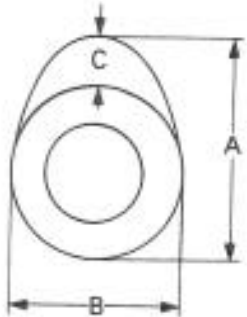
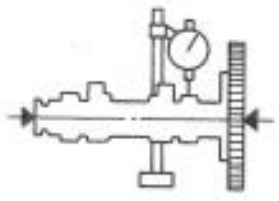
Engine

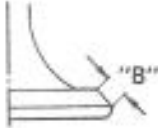
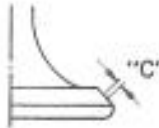

Model	SRX600S/SC
Cylinder Head: Warp Limit 	$< 0.03 \text{ mm (0.0012 in) } >$ *Lines indicate straightedge measurement.
Cylinder: Bore Size Measuring Point* Out of Round Limit 	95.00 ~ 95.02 mm (3.740 ~ 3.741 in) 40 mm (1.57 in) 0.05 mm (0.002 in)
Camshaft: Drive Method Cam Cap Inside Diameter Camshaft Outside Diameter Shaft-to-cap Clearance Cam Dimensions: Intake: "A" $< \text{Limit} >$ "B" $< \text{Limit} >$ "C" $< \text{Limit} >$ Exhaust: "A" $< \text{Limit} >$ "B" $< \text{Limit} >$ "C" Camshaft Runout Limit  	Chain (Left) 23.000 ~ 23.021 mm (0.9055 ~ 0.9063 in) 22.967 ~ 22.980 mm (0.9042 ~ 0.9047 in) 0.020 ~ 0.054 mm (0.0008 ~ 0.0021 in) 36.47 ~ 36.57 mm (1.436 ~ 1.440 in) $< 36.42 \text{ mm (1.434 in) } >$ 30.06 ~ 30.16 mm (1.183 ~ 1.187 in) $< 30.01 \text{ mm (1.182 in) } >$ 6.41 mm (0.252 in) 36.62 ~ 36.72 mm (1.442 ~ 1.446 in) $< 36.57 \text{ mm (1.440 in) } >$ 30.11 ~ 30.21 mm (1.185 ~ 1.189 in) $< 30.06 \text{ mm (1.184 in) } >$ 6.51 mm (0.256 in) $< 0.03 \text{ mm (0.001 in) } >$
Cam Chain Type/Number of Links Cam Chain Adjustment Method	75-010/126 Links Automatic
Rocker Arm/Rocker Arm Shaft: Arm Inside Diameter $< \text{Limit} >$ Shaft Outside Diameter $< \text{Limit} >$ Arm-to-shaft Clearance	12.000 ~ 12.018 mm (0.4724 ~ 0.4731 in) $< 12.05 \text{ mm (0.474 in) } >$ 11.976 ~ 11.991 mm (0.4715 ~ 0.4721 in) $< 11.95 \text{ mm (0.471 in) } >$ 0.009 ~ 0.042 mm (0.0004 ~ 0.0017 in)

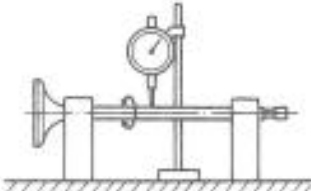

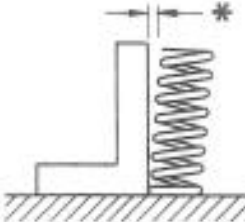
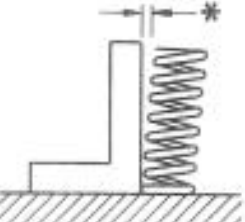
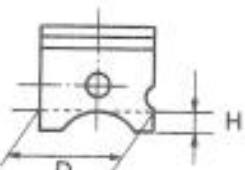
Model	SRX600S/SC	
Valve, Valve Seat, Valve Guide: Valve Clearance (Cold):	IN. EX.	0.05 ~ 0.10 mm (0.002 ~ 0.004 in) 0.12 ~ 0.17 mm (0.005 ~ 0.007 in)
Valve Dimensions:		
<div style="display: flex; justify-content: space-around;"> <div style="text-align: center;">  <p>Head Dia.</p> </div> <div style="text-align: center;">  <p>Face Width</p> </div> </div>	<div style="display: flex; justify-content: space-around;"> <div style="text-align: center;">  <p>Seat Width</p> </div> <div style="text-align: center;">  <p>Margin Thickness</p> </div> </div>	
"A" Head Diameter:	IN. EX.	35.9 ~ 36.1 mm (1.413 ~ 1.421 in) 30.9 ~ 31.1 mm (1.217 ~ 1.224 in)
"B" Face Width:	IN. EX.	2.26 mm (0.089 in) 2.26 mm (0.089 in)
"C" Seat Width:	IN. EX.	1.0 ~ 1.2 mm (0.039 ~ 0.047 in) 1.0 ~ 1.2 mm (0.039 ~ 0.047 in)
< Limit >	IN. EX.	< 2.0 mm (0.080 in) > < 2.0 mm (0.080 in) >
"D" Margin Thickness:	IN. EX.	1.0 ~ 1.4 mm (0.039 ~ 0.055 in) 0.8 ~ 1.2 mm (0.031 ~ 0.047 in)
< Limit >	IN. EX.	< 0.7 mm (0.028 in) > < 0.7 mm (0.028 in) >
Stem Outside Diameter:	IN. EX.	6.975 ~ 6.990 mm (0.2746 ~ 0.2752 in) 6.955 ~ 6.970 mm (0.2738 ~ 0.2744 in)
< Limit >	IN. EX.	< 6.945 mm (0.273 in) > < 6.915 mm (0.272 in) >
Guide Inside Diameter:	IN. EX.	7.000 ~ 7.012 mm (0.2756 ~ 0.2761 in) 7.000 ~ 7.012 mm (0.2756 ~ 0.2761 in)
< Limit >	IN. EX.	< 7.10 mm (0.280 in) > < 7.10 mm (0.280 in) >
Stem-to-guide Clearance:	IN. EX.	0.010 ~ 0.037 mm (0.0004 ~ 0.0015 in) 0.030 ~ 0.057 mm (0.0012 ~ 0.0022 in)
< Limit >	IN. EX.	< 0.10 mm (0.004 in) > < 0.12 mm (0.005 in) >
Stem Runout Limit		< 0.01 mm (0.0004 in) >
		

Model	SRX600S/SC	
<p>Valve Spring:</p> <p>Inner Spring:</p> <p>Free Length</p> <p>< Limit ></p> <p>Set Length (Valve Closed)</p> <p>Compressed Pressure (Installed)</p> <p>Tilt Limit *</p>  <p>Direction of Winding</p> <p>Outer Spring:</p> <p>Free Length</p> <p>< Limit ></p> <p>Set Length (Valve Closed)</p> <p>Compressed Pressure (Installed)</p> <p>Tilt Limit *</p>  <p>Direction of Winding</p>	<p>IN.</p> <p>EX.</p> <p>IN.</p> <p>EX.</p> <p>IN.</p> <p>EX.</p> <p>IN.</p> <p>EX.</p> <p>IN.</p> <p>EX.</p> <p>IN.</p> <p>EX.</p> <p>IN.</p> <p>EX.</p> <p>IN.</p> <p>EX.</p> <p>IN.</p> <p>EX.</p> <p>IN.</p> <p>EX.</p>	<p>40.1 mm (1.58 in)</p> <p>40.1 mm (1.58 in)</p> <p>< 38.1 mm (1.50 in) ></p> <p>< 38.1 mm (1.50 in) ></p> <p>22.7 mm (0.89 in)</p> <p>22.7 mm (0.89 in)</p> <p>16.8 ~ 19.4 kg (37.0 ~ 42.8 lb)</p> <p>16.8 ~ 19.4 kg (37.0 ~ 42.8 lb)</p> <p>< 2.5°/1.7 mm (0.067 in) ></p> <p>< 2.5°/1.7 mm (0.067 in) ></p> <p>Right</p> <p>Right</p> <p>43.8 mm (1.72 in)</p> <p>43.8 mm (1.72 in)</p> <p>< 41.8 mm (1.65 in) ></p> <p>< 41.8 mm (1.65 in) ></p> <p>34.2 mm (1.35 in)</p> <p>34.2 mm (1.35 in)</p> <p>37.1 ~ 49.6 kg (81.8 ~ 109.3 lb)</p> <p>37.1 ~ 49.6 kg (81.8 ~ 109.3 lb)</p> <p>< 2.5°/1.7 mm (0.067 in) ></p> <p>< 2.5°/1.7 mm (0.067 in) ></p> <p>Left</p> <p>Left</p>
<p>Piston:</p> <p>Piston Size "D"/ Measuring Point "H"</p> <p>Piston Clearance Oversize: 2nd 4th</p> 	<p>94.915 ~ 94.965 mm (3.737 ~ 3.739 in)/ 5 mm (0.20 in) (From bottom line of piston skirt)</p> <p>0.045 ~ 0.065 mm (0.0018 ~ 0.0026 in)</p> <p>95.50 mm (3.760 in)</p> <p>96.00 mm (3.780 in)</p>	

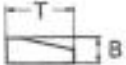

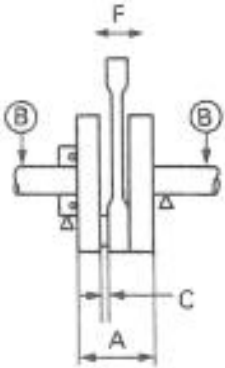
Model	SRX600S/SC	
<p>Piston Ring: Sectional Sketch:</p> <p>Top Ring </p> <p>2nd Ring </p> <p>Oil Ring </p> <p>End Gap (Installed):</p> <p>Top Ring</p> <p>2nd Ring</p> <p>Oil Ring</p> <p>< Limit ></p> <p>Side Clearance (Installed):</p> <p>Top Ring</p> <p>2nd Ring</p> <p>< Limit ></p>	<p>Barrel</p> <p>B = 1.2 mm (0.05 in)</p> <p>T = 3.8 mm (0.15 in)</p> <p>Taper</p> <p>B = 1.2 mm (0.05 in)</p> <p>T = 3.8 mm (0.15 in)</p> <p>Expander</p> <p>B = 2.5 mm (0.10 in)</p> <p>T = 3.4 mm (0.13 in)</p> <p>0.30 ~ 0.45 mm (0.012 ~ 0.018 in)</p> <p>0.30 ~ 0.45 mm (0.012 ~ 0.018 in)</p> <p>0.2 ~ 0.7 mm (0.008 ~ 0.028 in)</p> <p>< 0.60 mm (0.024 in) ></p> <p>< 0.60 mm (0.024 in) ></p> <p>0.04 ~ 0.08 mm (0.0016 ~ 0.0031 in)</p> <p>0.03 ~ 0.07 mm (0.0012 ~ 0.0028 in)</p> <p>< 0.10 mm (0.0039 in) ></p> <p>< 0.11 mm (0.0043 in) ></p>	
<p>Crankshaft:</p>  <p>Crank Width "A"</p> <p>< Runout Limit "B" ></p> <p>Small End Free Play "F"</p> <p>< Limit ></p> <p>Big End Radial Clearance "C"</p>	<p>74.95 ~ 75.00 mm (2.951 ~ 2.953 in)</p> <p>< 0.03 mm (0.001 in) ></p> <p>0.8 mm (0.031 in)</p> <p>< 2.0 mm (0.08 in) ></p> <p>0.25 ~ 0.75 mm (0.010 ~ 0.030 in)</p>	
<p>Balancer Drive Method</p>	<p>Gear</p>	
<p>Clutch:</p> <p>Friction Plate Thickness/Quantity</p> <p>Wear Limit</p> <p>Clutch Plate Thickness/Quantity</p> <p>Warp Limit</p> <p>Clutch Spring Free Length/Quantity</p> <p>Clutch Spring Minimum Length</p> <p>Push Rod Bending Limit</p>	<p>Type A: 2.90 ~ 3.10 mm (0.114 ~ 0.122 in)/2</p> <p>Type B: 2.72 ~ 2.88 mm (0.107 ~ 0.113 in)/6</p> <p>Type A: < 2.80 mm (0.110 in) ></p> <p>Type B: < 2.60 mm (0.102 in) ></p> <p>1.2 mm (0.047 in)/7</p> <p>< 0.2 mm (0.008 in) ></p> <p>42.8 mm (1.69 in)/5</p> <p>40.8 mm (1.61 in)</p> <p>< 0.5 mm (0.02 in) ></p>	



Model	SRX600S/SC	
Transmission: Main Axle Deflection Limit Drive Axle Deflection Limit	< 0.08 mm (0.0031 in) > < 0.08 mm (0.0031 in) >	
Kick Starter: Kick Starter Type	Ratchet Type	
Decompression Device: Type Cable Free Play	Kick synchronous 3 ~ 5 mm (0.12 ~ 0.20 in)	
Air Filter Oil Grade (Oiled Filter)	SAE 10W30 SE motor oil	
Carburetor: I.D. Mark	SRX600S: 2EF00	SRX600SC: 2EG00
	Primary carburetor	Secondary carburetor
Main Jet (M.J.)	#118	#100
Main Air Jet (M.A.J.)	φ0.8	φ1.3
Jet Needle-Clip Position (J.N.)	5C3F-1/1	5Z71-1/1
Main Nozzle (M.N.)	φ2.60	φ2.60
Cutaway (C.A.)	#5.5	
Pilot Jet (P.J.)	#46	
Pilot Air Jet (P.A.J.)	φ0.6	
Enricher Air Jet (E.A.J.)	φ1.1	
Pilot Screw (P.S.)	Preset	
Valve Seat (V.S.)	φ2.5	
Starter Jet (G.S.)	φ0.64	
Fuel Level (F.L.)	6.5 ~ 7.5 mm (0.26 ~ 0.30 in)	
Float Level	26 ~ 28 mm (1.02 ~ 1.10 in)	
Engine Idling Speed	1,250 ~ 1,350 r/min	
Vacuum Pressure at Idling Speed	26.6 kPa (200 mmHg, 7.9 inHg) or more	
Lubrication System:	Paper, Wire mesh	
Oil Filter Type	Trochoid pump	
Oil Pump Type	0.12 mm (0.005 in)	
Tip Clearance	< 0.17 mm (0.007 in) >	
< Limit >	0.03 ~ 0.08 mm (0.001 ~ 0.003 in)	
Side Clearance	< 0.08 mm (0.003 in) >	
< Limit >	78.5 ~ 117.7 kPa	
Bypass Valve Setting Pressure	(0.8 ~ 1.2 kg/cm ² , 11.4 ~ 17.1 psi)	
Relief Valve Operating Pressure	78.5 ~ 117.7 kPa	
	(0.8 ~ 1.2 kg/cm ² , 11.4 ~ 17.1 psi)	

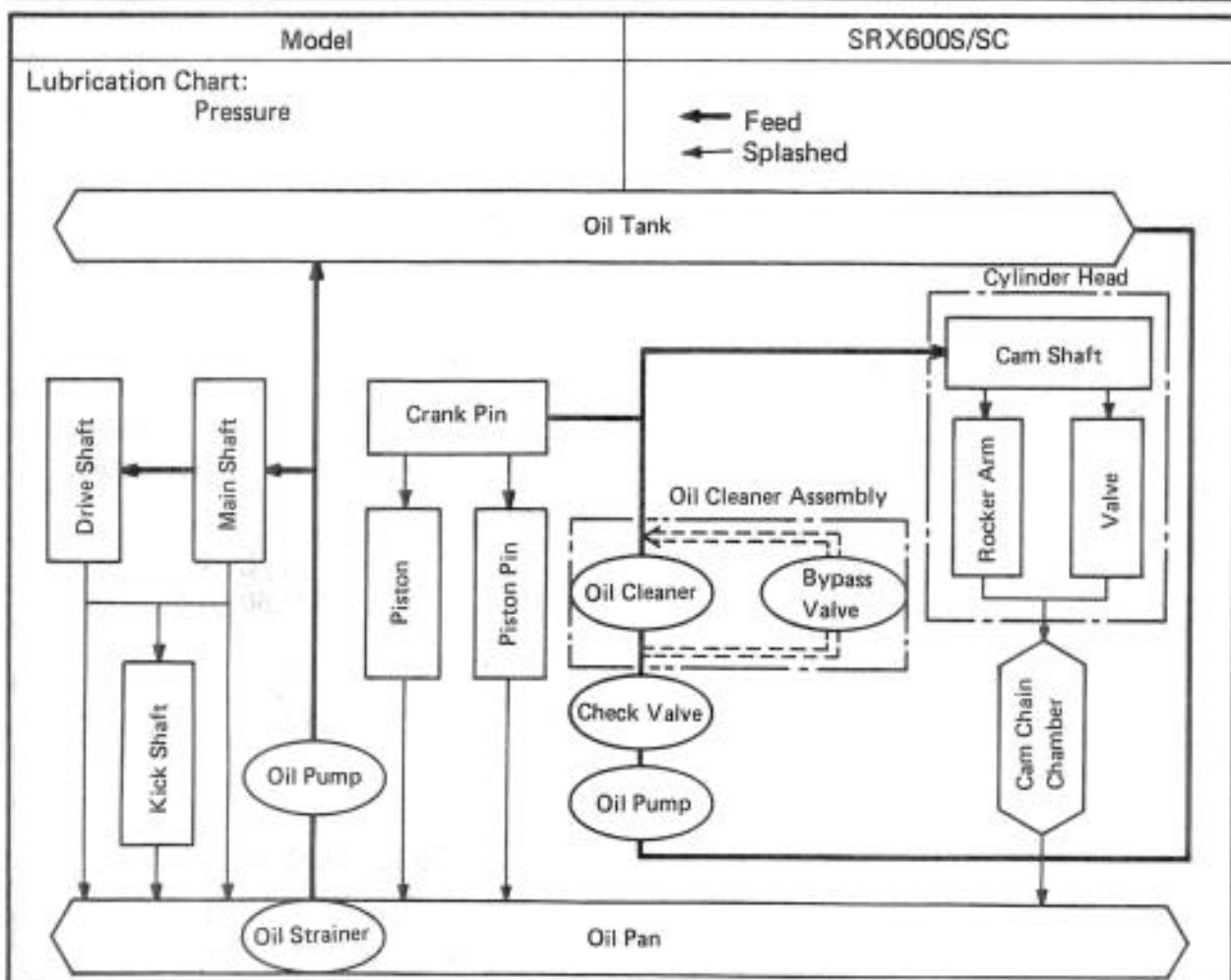

Crankcase Tightening Sequence:
Left Side

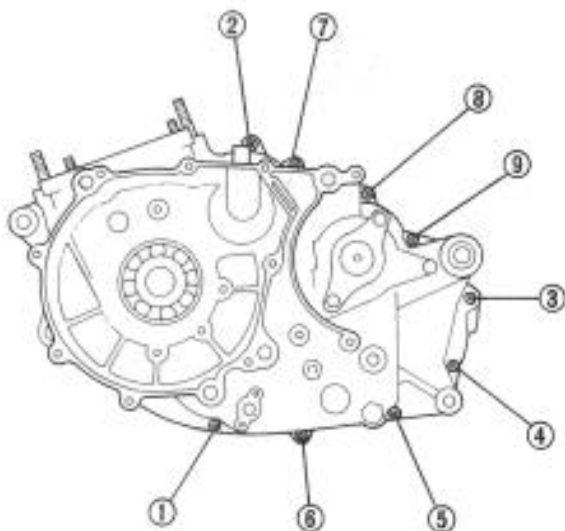

Right Side

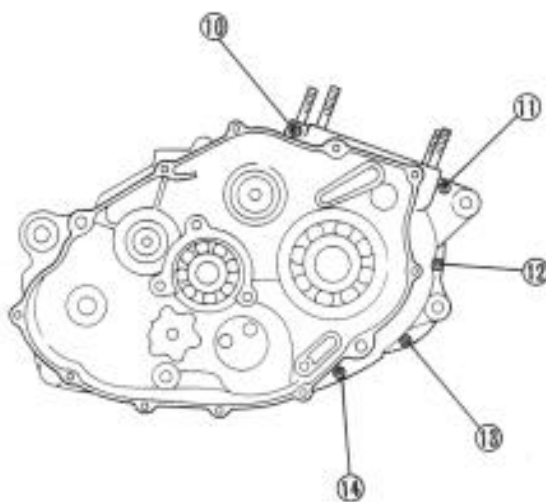



Tightening Torque							
Parts to be tightened	Part name	Thread size	Q'ty	Tightening torque			Remarks
				Nm	m·kg	ft·lb	
ENGINE:							
Cylinder Head	Flange bolt	M8 x 1.25	4	25	2.5	18	Use lock washer
	Nut	M10 x 1.25	2	20	2.0	14	
	Bolt	M6	1	10	1.0	7.2	
	Stud bolt	M6	4	7	0.7	5.1	
Spark Plug	—	M12 x 1.25	1	17.5	1.75	12.5	
Cylinder Head Cover	Bolt	M6	16	10	1.0	7.2	
	Tappet Cover	Bolt	2	10	1.0	7.2	
Cylinder	Bolt	M32 x 1.5	2	12	1.2	8.7	
	Cap nut	M8 x 1.25	2	22	2.2	16	
	Nut	M10 x 1.25	4	38	3.8	27	
Balance Weight Gear	Bolt	M6 x 1.25	2	10	1.0	7.2	
	Nut	M16 x 1.0	1	90	9.0	65	
A.C. Generator Rotor	Nut	M14 x 1.5	1	90	9.0	65	
Valve Clearance	Nut	M6	4	14	1.4	10	
Stopper Guide	Bolt	M6	2	8	0.8	5.8	
Cam Sprocket	Flange bolt	M7	2	20	2.0	14	
Tensioner Assembly	Bolt	M6	2	10	1.0	7.2	
Decompression Cam	Bolt	M6	1	8	0.8	5.8	
Rocker Shaft Stopper	Bolt	M6	2	10	1.0	7.2	
Oil Pump Assembly	Bolt	M6	3	10	1.0	7.2	
Oil Pump Cover	Screw	M6	1	7	0.7	5.1	
Strainer Housing	Screw	M6	2	7	0.7	5.1	
Drain Plug	Plug	M14 x 1.5	1	30	3.0	22	
Oil Filter Cover	Bolt	M6	3	10	1.0	7.2	
Oil Filter Air Bleed	Screw	M5	1	5	0.5	3.6	
Oil Hose	Bolt	M6	4	10	1.0	7.2	
	Union nut	M16 x 1.5	2	50	5.0	36	
Carburetor Joint	Bolt	M6	4	10	1.0	7.2	
Carburetor Assembly	Hose clamp	M4	2	2	0.2	1.4	
Exhaust Pipe	Nut	M6	4	10	1.0	7.2	
Exhaust Pipe Protector	Screw	M6	2	7	0.7	5.1	
Outlet Pipe	Screw	M6	1	7	0.7	5.1	
Exhaust Pipe Muffler Joint	Bolt	M8 x 1.25	1	20	2.0	14	
Muffler Mounting	Bolt	M8 x 1.25	2	27	2.7	19	
Crankcase	Bolt	M6	14	10	1.0	7.2	
Crankcase	Stud bolt	M10 x 1.25	4	20	2.0	14	
Clamp (Lead)	Screw	M6	1	7	0.7	5.1	
Decompression Cover	Bolt	M6	2	10	1.0	7.2	
Bridge Plate Cover	Screw	M6	3	7	0.7	5.1	
Ratchet Wheel Guide	Bolt	M6	2	10	1.0	7.2	
Decompression Lever	Nut	M6	1	8	0.8	5.8	



Parts to be tightened	Part name	Thread size	Q'ty	Tightening torque			Remarks
				Nm	m·kg	ft·lb	
Clutch Boss	Nut	M20 x 1.0	1	70	7.0	50	Use lock washer
Primary Drive Gear	Nut	M20 x 1.0	1	110	11.0	80	Use lock washer
Push Lever Stopper	Screw	M8 x 1.0	1	12	1.2	8.7	
Push Lever Positioning	Nut	M6	1	8	0.8	5.8	
Drive Sprocket	Bolt	M6	2	10	1.0	7.2	
Oil Seal Cover	Bolt	M6	2	10	1.0	7.2	
Stopper Lever	Nut	M6	1	10	1.0	7.2	
Shift Pedal	Bolt	M6	1	10	1.0	7.2	
Coil	Screw	M6	6	7	0.7	5.1	
Tensioner End Plug	Plug	M32 x 1.5	1	20	2.0	14	
Kick crank	Nut	M14	1	50	5.0	36	



Chassis

Model	SRX600S/SC
Steering System: Steering Bearing Type	Ball bearing
Front Suspension: Front Fork Travel Fork Spring Free Length < Limit > Collar Length Spring Rate/Stroke: K1 K2 Oil Capacity or Oil Level Oil Grade	140 mm (5.5 in) 499 mm (19.6 in) < 494 mm (19.5 in) > 70 mm (2.8 in) 3.68 N/mm (0.375 kg/mm, 21.0 lb/in)/ 0 ~ 84.5 mm (0 ~ 3.33 in) 5.39 N/mm (0.55 kg/mm, 30.8 lb/in)/ 84.5 ~ 150 mm (3.33 ~ 5.91 in) 310 cm ³ (10.9 Imp oz, 10.5 US oz) 152 mm (5.98 in) (From top of inner tube fully compressed without spring.) Yamaha fork oil 10Wt or equivalent
Rear Suspension: Shock Absorber Travel Spring Free Length < Limit > Fitting Length Spring Rate/Stroke: K1 K2 Enclosed Gas Pressure: Standard Minimum ~ Maximum	75 mm (2.95 in) 240.5 mm (9.47 in) < 238 mm (9.37 in) > 215.5 mm (8.48 in) 16.2 N/mm (1.65 kg/mm, 92.4 lb/in)/ 0 ~ 40.5 mm (0 ~ 1.59 in) 20.6 N/mm (2.1 kg/mm, 117.6 lb/in)/ 40.5 ~ 75.0 mm (1.59 ~ 2.95 in) 981 kPa (10 kg/cm ² , 142 psi) 883 ~ 1,079 kPa (9 ~ 11 kg/cm ² , 128 ~ 156 psi)
Swingarm: Swingarm Free Play Limit: End	< 1.0 mm (0.04 in) >
Wheel: Front Wheel Type Rear Wheel Type Rim Size/Material: Front Rear Rim Runout Limit: Vertical Lateral	Cast Wheel Cast Wheel MT2.15 x 18/Aluminum MT2.75 x 18/Aluminum < 2.0 mm (0.08 in) > < 2.0 mm (0.08 in) >
Drive Chain: Type/Manufacturer Number of Links Chain Slack	520VSR/DAIDO 104 Links 15 ~ 20 mm (0.6 ~ 0.8 in)



Model	SRX600S/SC
Front Disc Brake: Type Outside Diameter x Thickness < Limit > Pad Thickness < Limit > Master Cylinder Inside Diameter Caliper Cylinder Inside Diameter Brake Fluid Type	Dual disc 267 x 5 mm (10.5 x 0.20 in) < 4.5 mm (0.18 in) > 5.5 mm (0.22 in) < 0.5 mm (0.02 in) > 15.8 mm (0.62 in) 38.18 mm (1.50 in) DOT #3
Rear Disc Brake: Type Outside Diameter x Thickness < Limit > Pad Thickness < Limit > Master Cylinder Inside Diameter Caliper Cylinder Inside Diameter Brake Fluid Type	Single disc 245 x 5 mm (9.6 x 0.20 in) < 4.5 mm (0.18 in) > 5.5 mm (0.22 in) < 0.5 mm (0.02 in) > 14 mm (0.55 in) 38.18 mm (1.50 in) DOT #3
Brake Lever & Brake Pedal: Brake Lever Free Play Brake Pedal Position	2 ~ 5 mm (0.08 ~ 0.20 in) 50 mm (2.0 in) Below the top of the footrest
Clutch Lever Free Play/Position	2 ~ 3 mm (0.08 ~ 0.12 in)/at lever pivot



Tightening Torque

Parts to be tightened	Thread size	Tightening torque			Remarks
		Nm	m·kg	ft·lb	
CHASSIS:					
Front Wheel Axle	M14 x 1.5	105	10.5	75	See NOTE
Rear Wheel Axle	M16 x 1.5	105	10.5	75	
Front Fork and Fork Brace	M6 x 1.0	9	0.9	6.5	
Steering Crown and Inner Tube	M8 x 1.25	20	2.0	14	
Steering Crown and Steering Shaft	M22 x 1.0	110	11.0	80	
Handlebar and Inner Tube	M8 x 1.25	20	2.0	14	
Handlebar and Steering Crown	M6 x 1.0	9	0.9	6.5	
Steering Shaft and Ring Nut	M25 x 1.0	38	3.8	27	
Front Master Cylinder and Master Bracket	M6 x 1.0	9	0.9	6.5	
Front Master Cylinder and Master Cylinder Cap	M5 x 0.8	1	0.1	0.7	
Brake Hose and Union Bolt	M10 x 1.25	25	2.5	18	
Brake Joint and Under Bracket	M6 x 1.0	9	0.9	6.5	
Caliper and Bleed Screw	M8 x 1.25	5	0.5	3.6	
Front Caliper and Front Fork	M10 x 1.25	35	3.5	25	
Engine Stay and Frame	M8 x 1.25	33	3.3	24	
Engine Mounting (Front Upper)	M10 x 1.25	42	4.2	30	
Engine Mounting (Front Lower)	M10 x 1.25	42	4.2	30	
Engine Mounting (Rear Upper)	M10 x 1.25	42	4.2	30	
Engine Mounting (Rear Under)	M10 x 1.25	42	4.2	30	
Engine Stay and Frame (Top)	M8 x 1.25	33	3.3	24	
Engine Mounting (Top)	M10 x 1.25	42	4.2	30	
Frame and Down Tube	M8 x 1.25	25	2.5	18	
Pivot Shaft	M14 x 1.5	90	9.0	65	
Rear Shock Absorber (Top)	M8 x 1.25	26	2.6	19	
Rear Shock Absorber (Bottom)	M10 x 1.25	41	4.1	30	
Rear Master Cylinder and Frame	M8 x 1.25	20	2.0	14	
Footrest Bracket and Frame	M8 x 1.25	26	2.6	19	
Brake Disc and Cast Wheel	M8 x 1.25	20	2.0	14	
Rear Caliper and Caliper Bracket	M10 x 1.25	35	3.5	25	
Rear Sprocket Wheel	M8 x 1.25	32	3.2	23	
Tension Bar	M8 x 1.25	25	2.5	18	
Kick Crank Stopper and Frame	M8 x 1.25	25	2.5	18	
Swingarm End and Swingarm	M6 x 1.0	6	0.6	4.3	
Inner Tube and Under Bracket	M12 x 1.25	38	3.8	27	
Cross Tube and Down Tube	M10 x 1.25	35	3.5	25	
Rear Footrest Bracket and Frame	M10 x 1.25	64	6.4	46	
Rear Footrest Bracket and Frame	M10 x 1.25	30	3.0	22	

NOTE:

1. First, tighten the ring nut approximately 38 Nm (3.8 m·kg, 27 ft·lb) by using the torque wrench, then loosen the ring nut one turn.
2. Retighten the ring nut 10 Nm (1.0 m·kg, 7.2 ft·lb).



Electrical

Model	SRX600S/SC
Voltage	12V
Ignition System: Ignition Timing (B.T.D.C.) Advancer Type	12° at 1,200 r/min Electrical
CDI: Magneto-Model/Manufacturer Pickup Coil Resistance (Color) Source Coil Resistance (Color) CDI Unit-Model/Manufacturer	VCD48/NIPPONDENSO 92 ~ 138Ω at 20°C (68° F) (Green - White/Green) (Green - White/Red) 84 ~ 156Ω at 20°C (68° F) (Brown - Red) QAB50/NIPPONDENSO
Ignition Coil: Model/Manufacturer Minimum Spark Gap Primary Winding Resistance Secondary Winding Resistance Spark Plug Cap Resistance	12970-102/NIPPONDENSO 6 mm (0.24 in) 0.48 ~ 0.72Ω at 20°C (68° F) 5.2 ~ 7.8 kΩ at 20°C (68° F) 5 kΩ
Charging System	AC Magneto generator
AC Generator: Model/Manufacturer Nominal Output	VCD48/NIPPON DENSO 14.5V, 11A at 5,000 r/min



Model	SRX600S/SC
Charging Coil Resistance (Color)	0.2 ~ 0.6Ω at 20°C (68°F) (Yellow – White/Yellow)
Voltage Regulator: Type Model/Manufacturer No Load Regulated Voltage	Short control SH565/SHINDENGEN 14 ~ 15V
Rectifier: Model/Manufacturer Capacity Withstand Voltage	SH565/SHINDENGEN 12A 200V
Battery: Capacity Specific Gravity	12V, 5AH 1.280
Horn: Type/Quantity Model/Manufacturer Maximum Amperage	Plain type/1 MF-12/NIKKO 1.5A
Flash Relay: Type Model/Manufacturer Self Cancelling Device Flasher Frequency Wattage	Condenser type FU257CD/NIPPONDENSO Yes 75 ~ 95 cycle/min 27W x 2 + 3.4W
Circuit Breaker: Type	Non fuse breaker



GENERAL TORQUE SPECIFICATIONS

This chart specifies torque for standard fasteners with standard I.S.O. pitch threads. Torque specifications for special components or assemblies are included in the applicable sections of this book. To avoid warpage, tighten multi-fastener assemblies in a crisscross fashion, in progressive stages, until full torque is reached. Unless otherwise specified, torque specifications call for clean, dry threads. Components should be at room temperature.

A (Nut)	B (Bolt)	General torque specifications		
		Nm	m·kg	ft·lb
10 mm	6 mm	6	0,6	4,3
12 mm	8 mm	15	1,5	11
14 mm	10 mm	30	3,0	22
17 mm	12 mm	55	5,5	40
19 mm	14 mm	85	8,5	61
22 mm	16 mm	130	13,0	94

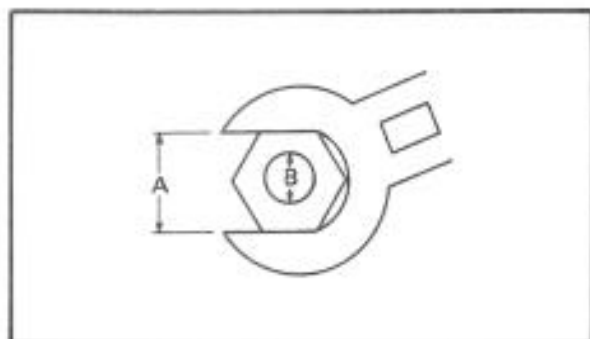

A: Distance across flats
B: Outside thread diameter

DEFINITION OF UNITS

Unit	Read	Definition	Measure
mm	millimeter	10^{-3} meter	Length
cm	centimeter	10^{-2} meter	Length
kg	kilogram	10^3 gram	Weight
N	Newton	$1 \text{ kg} \times \text{m}/\text{sec}^2$	Force
Nm	Newton meter	$\text{N} \times \text{m}$	Torque
m·kg	Meter kilogram	$\text{m} \times \text{kg}$	Torque
Pa	Pascal	N/m^2	Pressure
N/mm	Newton per millimeter	N/mm	Spring rate
L	Liter	—	Volume or Capacity
cm^3	Cubic centimeter	—	Volume or Capacity
r/min	Rotation per minute	—	Engine Speed



CONVERSION TABLES

Metric to inch system		
Known	Multiplier	Result
m·kg	7.233	ft·lb
m·kg	86.80	in·lb
cm·kg	0.0723	ft·lb
cm·kg	0.8680	in·lb
kg	2.205	lb
g	0.03527	oz
km/lit	2.352	mpg
km/hr	0.6214	mph
km	0.6214	mi
m	3.281	ft
m	1.094	yd
cm	0.3937	in
mm	0.03937	in
cc (cm ³)	0.03382	oz (US liq)
cc (cm ³)	0.06102	cu in
lit (liter)	2.1134	pt (US liq)
lit (liter)	1.057	qt (US liq)
lit (liter)	0.2642	gal (US liq)
kg/mm	56.007	lb/in
kg/cm ²	14.2234	psi (lb/in ²)
Centigrade (°C)	9/5 (°C) + 32	Fahrenheit (°F)

Inch to metric system		
Known	Multiplier	Result
ft·lb	0.13826	m·kg
in·lb	0.01152	m·kg
ft·lb	13.831	cm·kg
in·lb	1.1521	cm·kg
lb	0.4535	kg
oz	28.352	g
mpg	0.4252	km/lit
mph	1.609	km/hr
mi	1.609	km
ft	0.3048	m
yd	0.9141	m
in	2.54	cm
in	25.4	mm
oz (US liq)	29.57	cc (cm ³)
cu in	16.387	cc (cm ³)
pt (US liq)	0.4732	lit (liter)
qt (US liq)	0.9461	lit (liter)
gal (US liq)	3.785	lit (liter)
lb/in	0.017855	kg/mm
psi (lb/in ²)	0.07031	kg/cm ²
Fahrenheit (°F)	5/9 (°F - 32)	Centigrade (°C)

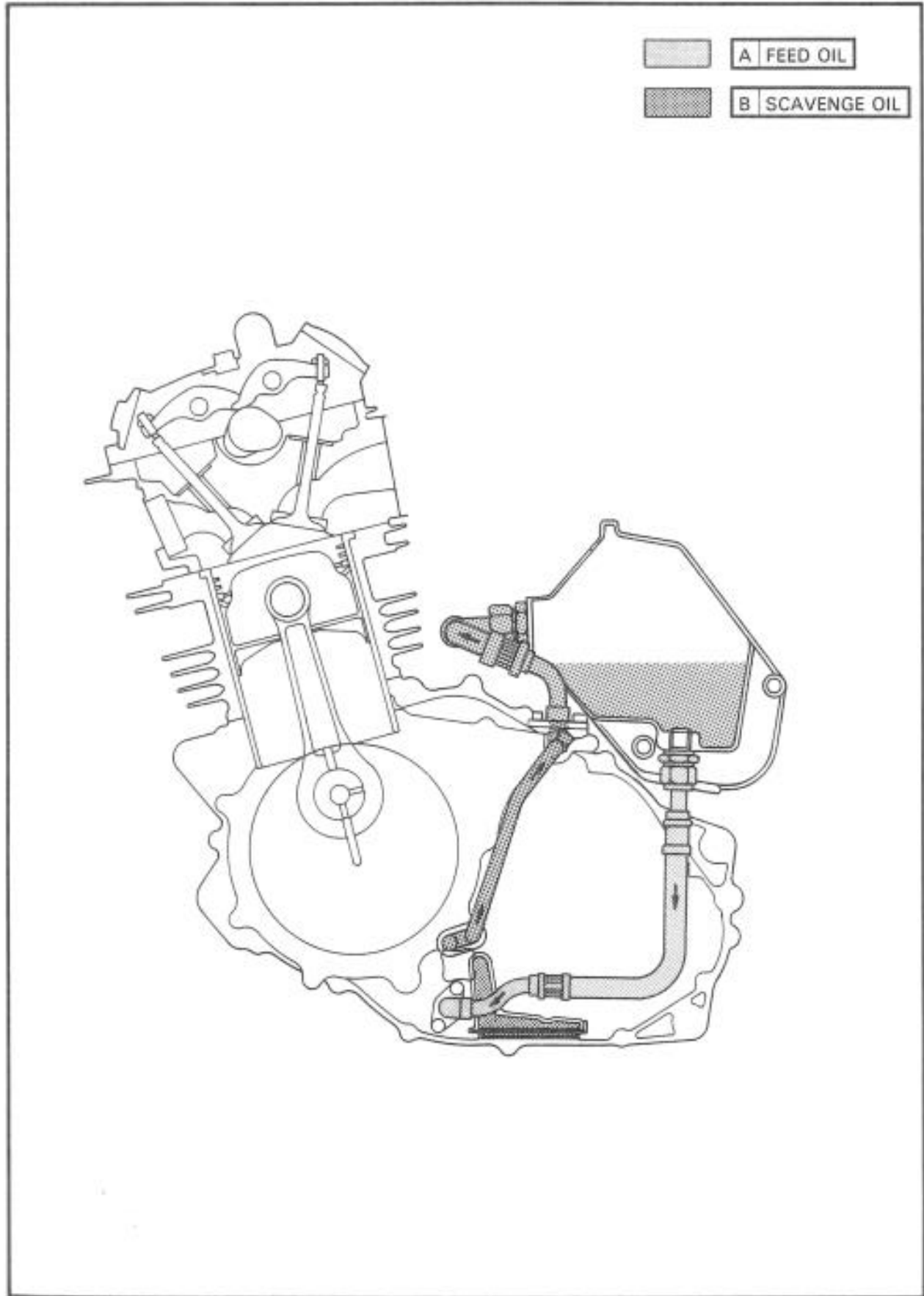
LUBRICATION DIAGRAM



-  A FEED OIL
-  B SCAVENGE OIL

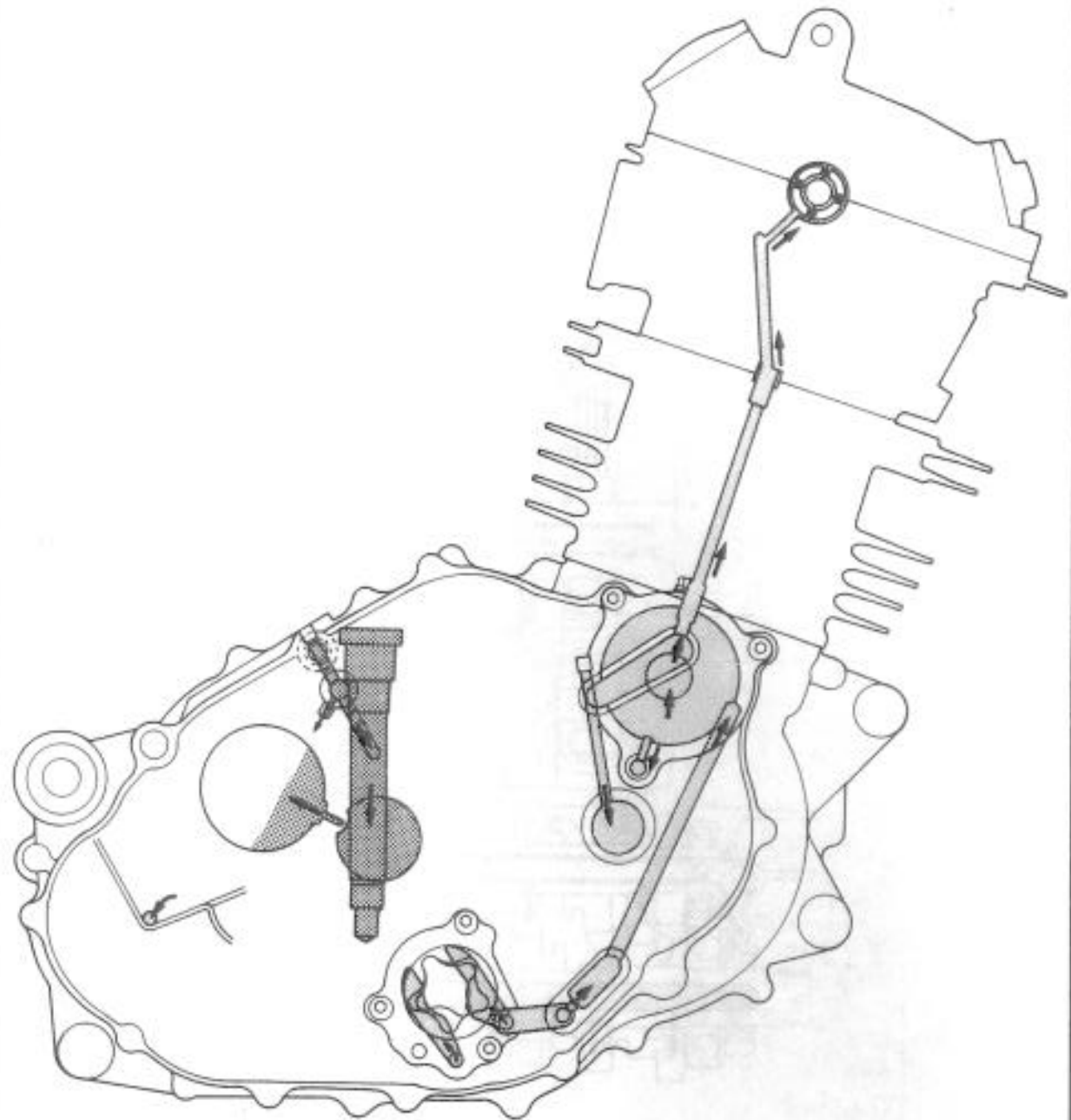

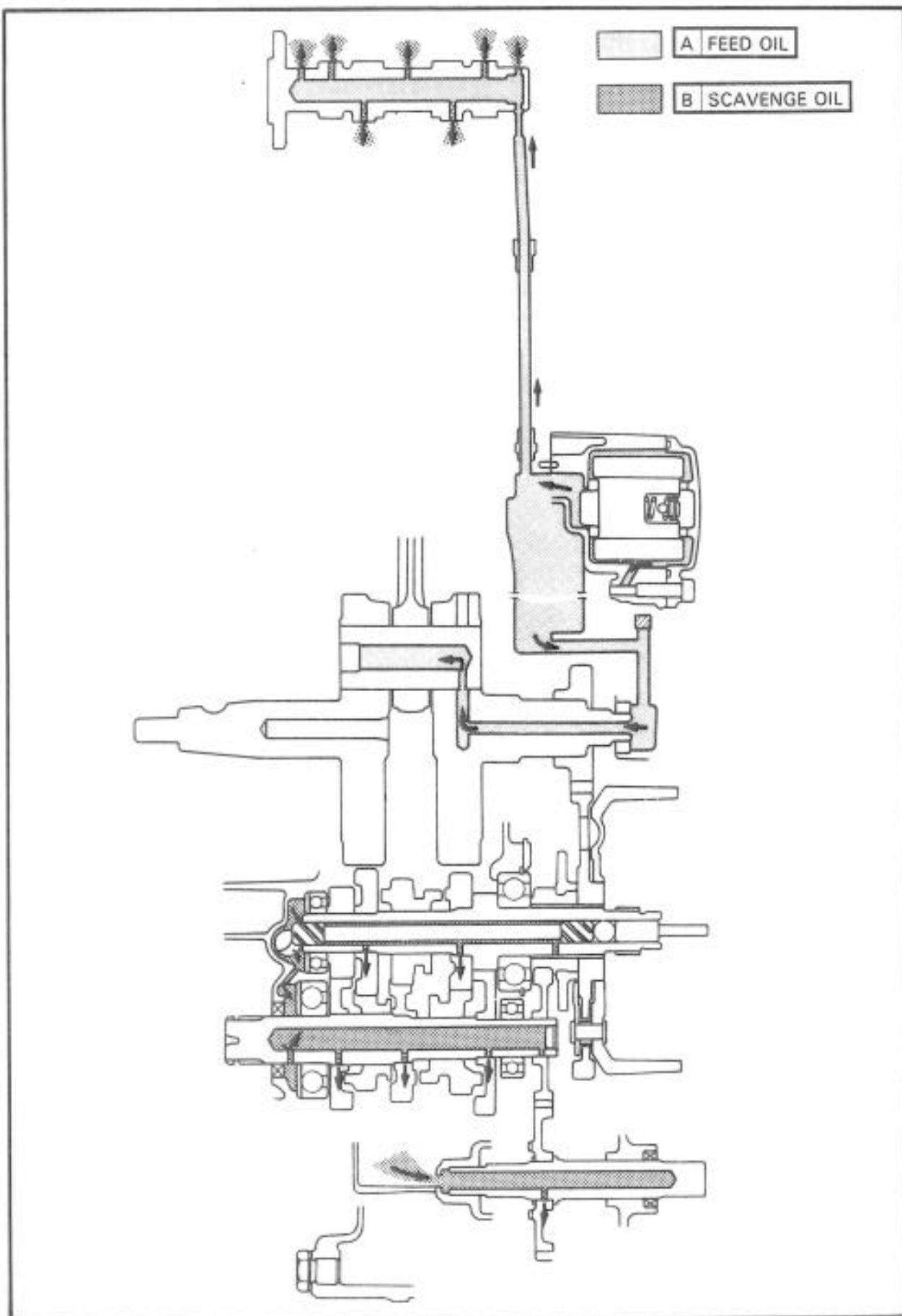

 A FEED OIL

 B SCAVENGE OIL

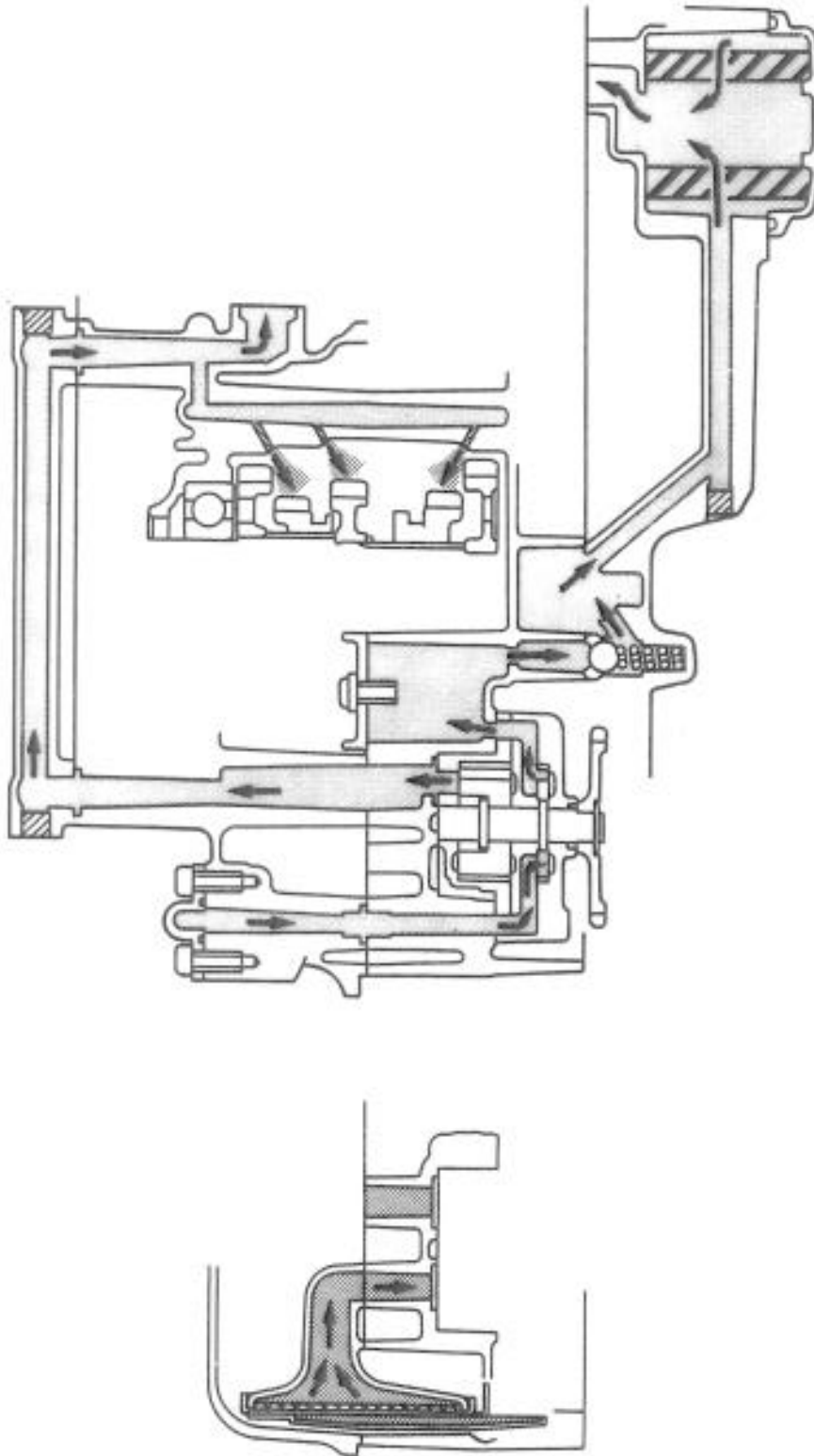

CABLE ROUTING

- ① Meter light lead
- ② Clutch cable
- ③ Handlebar switch (Left) lead
- ④ Starter cable
- ⑤ Main switch lead
- ⑥ Wire harness
- ⑦ Speedometer cable
- ⑧ Front flasher light leads (Left and right)

- ⑨ Tachometer cable
- ⑩ Throttle cables
- ⑪ Handlebar switch (Right) lead
- ⑫ Front brake switch lead
- ⑬ Brake hose

- A** Connect the lead into the headlight body.
- B** Pass the handlebar switch (Left) lead behind the clutch cable, and connect the lead into the headlight body.
- C** Cross the wire harness in front of the steering head pipe.
- D** Pass the handlebar switch (Right) lead behind the brake hose, and connect the lead into the headlight body.

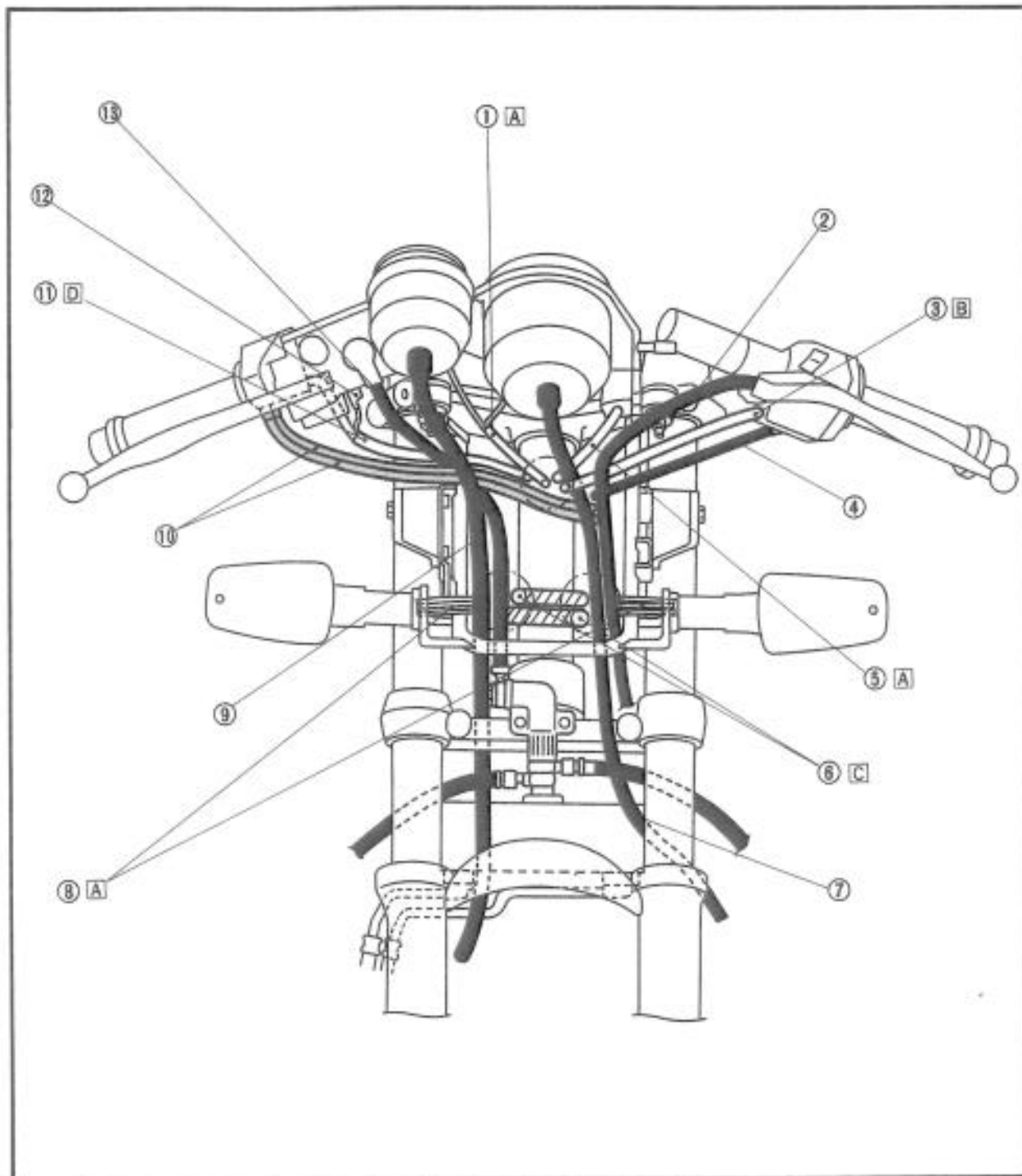

- | | | |
|---------------------------|--------------------------|---|
| ① Throttle cables | ⑨ Battery breather hose | ⑰ Ignition coil lead |
| ② Clamp | ⑩ Rear brake switch lead | ⑱ Ignition coil |
| ③ Brake hose | ⑪ Reservoir tank hose | ⑲ Ground lead |
| ④ Tachometer cable | ⑫ Taillight lead | ⑳ Flasher relay |
| ⑤ High tension cord | ⑬ Battery | A Pass the hoses into the guides. |
| ⑥ Overflow hose | ⑭ Wire harness | B Pass the hoses outside of the reservoir tank hose. |
| ⑦ Rear brake switch | ⑮ Ventilation hose | C Pass the breather hose between the primary and secondary carburetors. |
| ⑧ Fuel tank breather hose | ⑯ Oil tank breather hose | |

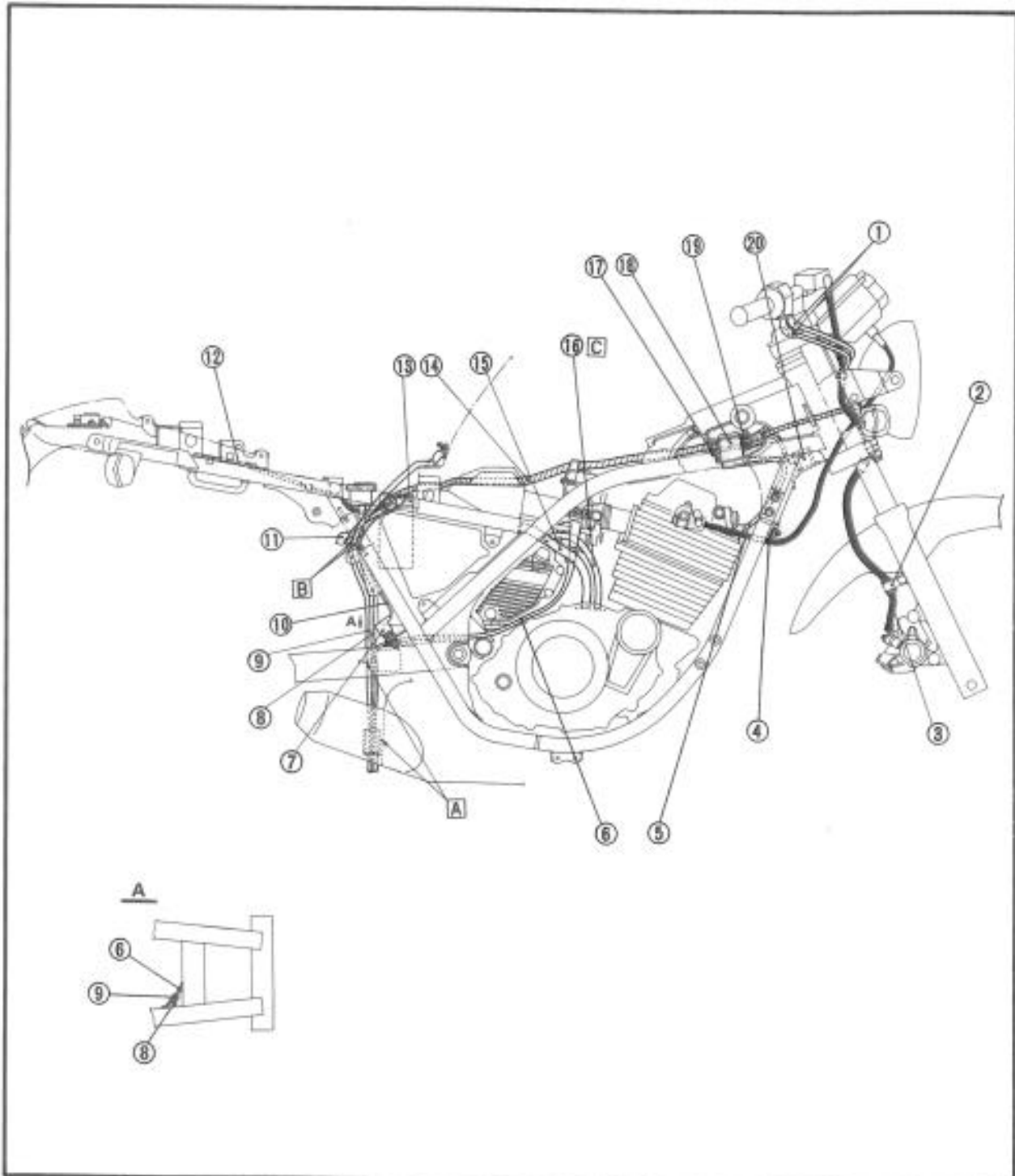



- | | | |
|----------------------------|---------------------|---|
| ① Clamp | ⑨ CDI unit lead | A Pass the hoses at the back of the oil tank. |
| ② Wire harness | ⑩ Oil tank hose | B Pass the speedometer cable into the cable holder. |
| ③ Band | ⑪ Clutch cable | |
| ④ Throttle cables | ⑫ Speedometer cable | |
| ⑤ Starter cable | ⑬ Brake hose | |
| ⑥ Air vent hose | | |
| ⑦ Rectifier/Regulator lead | | |
| ⑧ CDI unit | | |

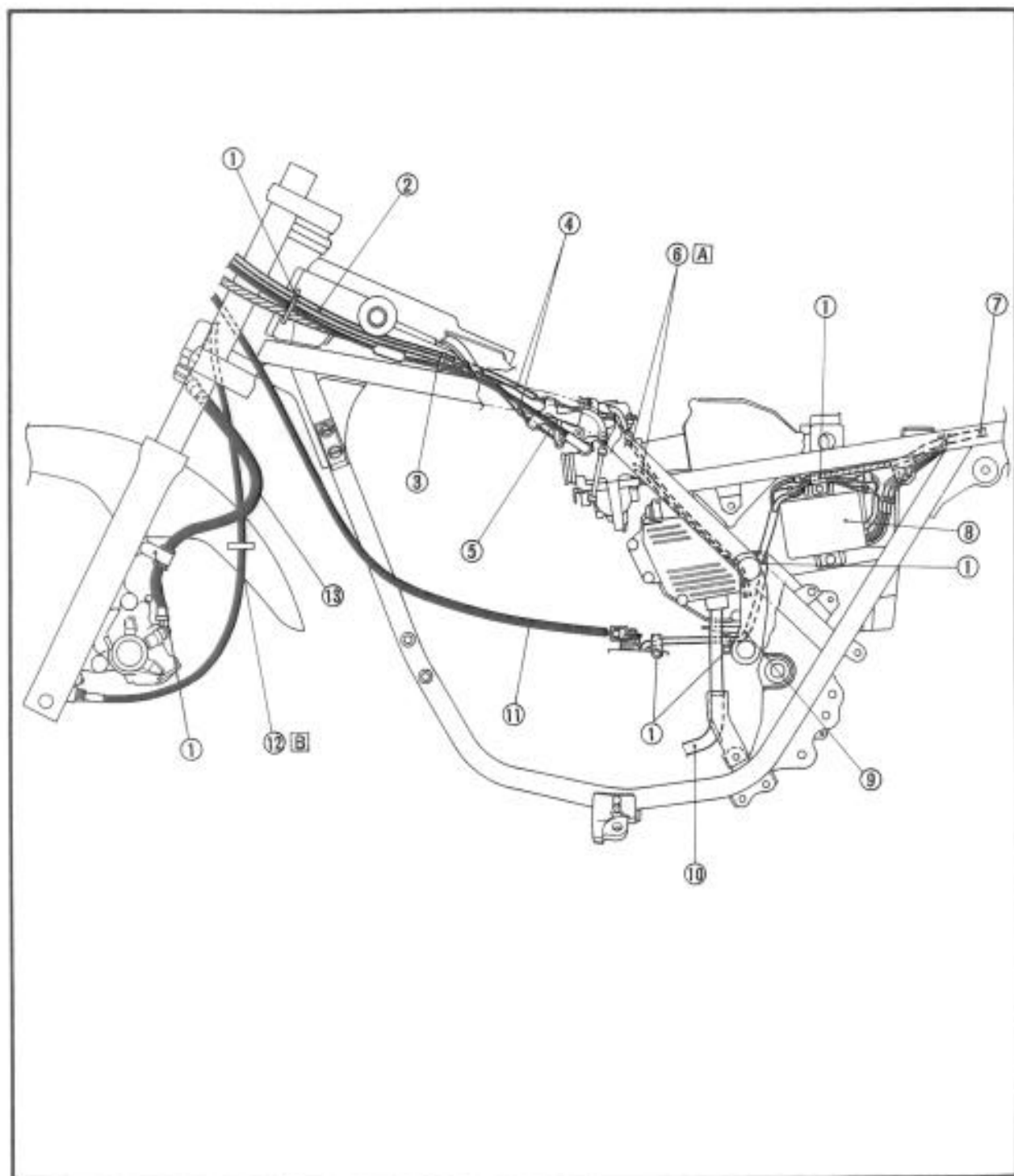



- ① Horn
- ② Clamp
- ③ Carburetor
- ④ Wire harness
- ⑤ Battery positive lead
- ⑥ Brake reservoir tank
- ⑦ Rear flasher light lead (Right)
- ⑧ Taillight lead
- ⑨ Rectifier/Regulator
- ⑩ Rear flasher light (Left)
- ⑪ To CDI unit lead
- ⑫ To CDI unit
- ⑬ Circuit breaker
- ⑭ Battery negative lead
- ⑮ Fuel tank breather hose

- A White taping:
Match the white tape to the main pipe end.
- B Pass the lead between the mud guard and frame.

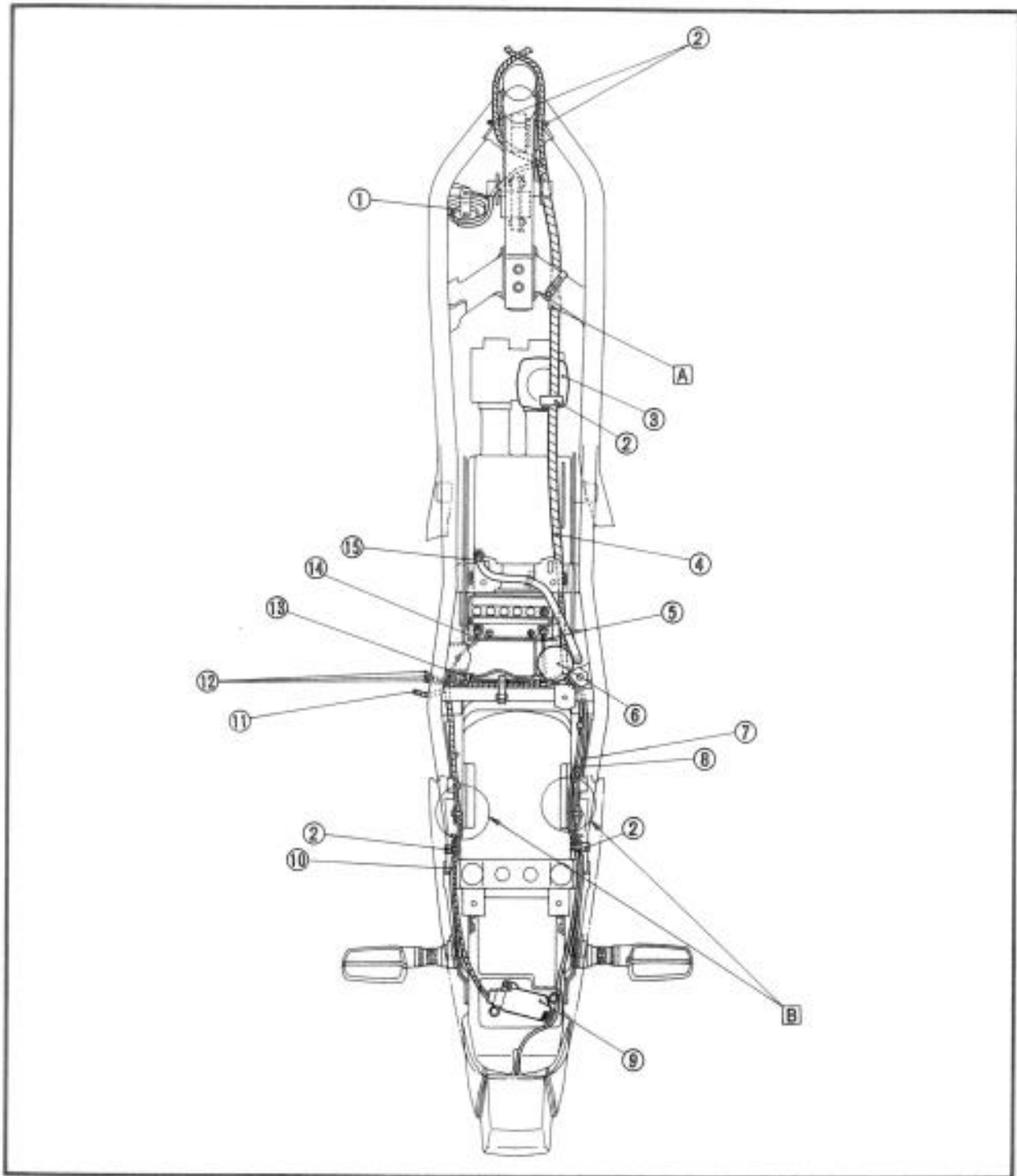

SRX600S/SRX600SC WIRING DIAGRAM

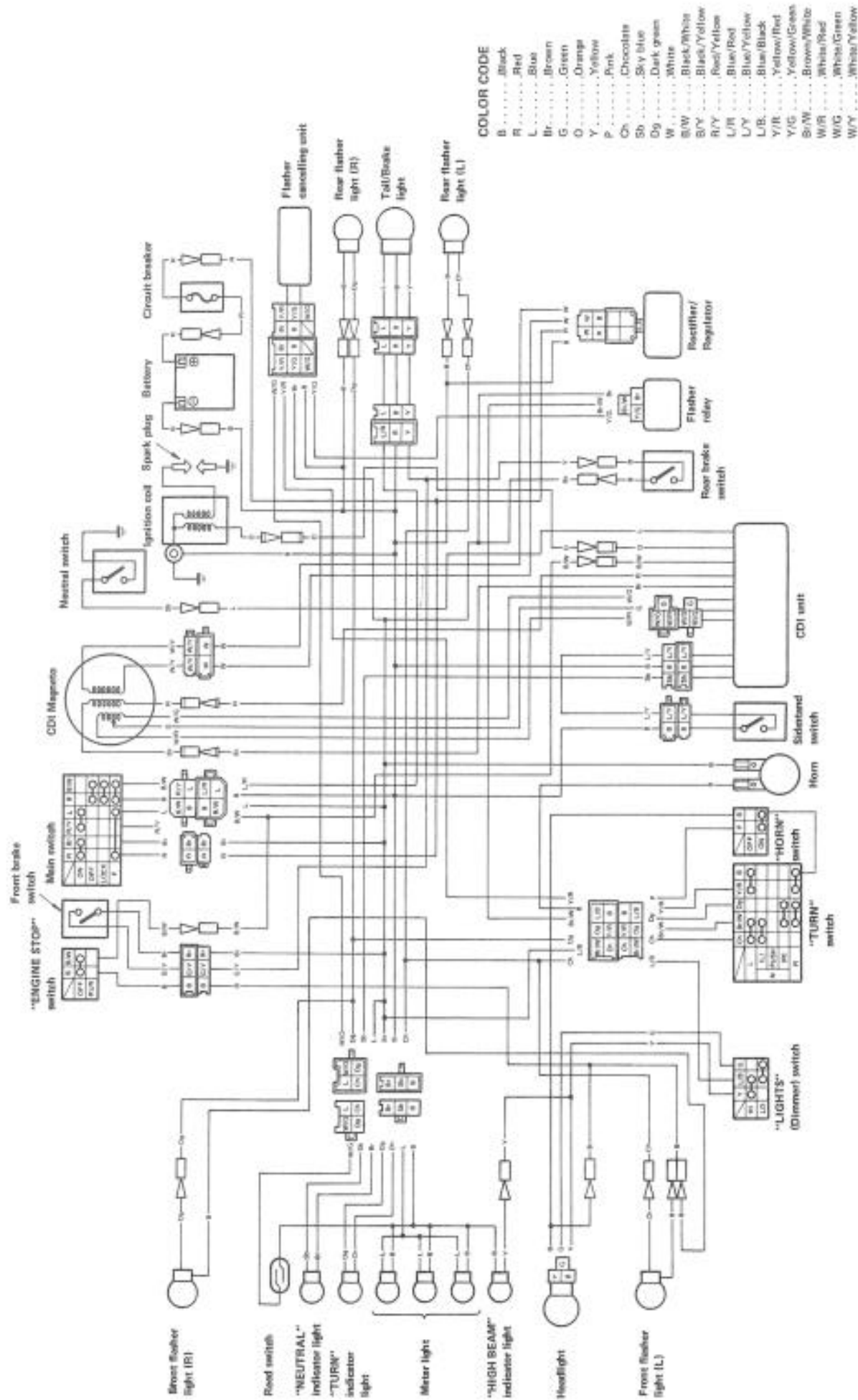

COLOR CODE

B	Black
R	Red
L	Blue
Br	Brown
G	Green
O	Orange
Y	Yellow
P	Pink
Ch	Chocolate
Sb	Sky blue
Dg	Dark green
W	White
B/W	Black/White
B/Y	Black/Yellow
R/Y	Red/Yellow
L/R	Blue/Red
L/Y	Blue/Yellow
L/B	Blue/Black
Y/R	Yellow/Red
Y/G	Yellow/Green
B/W	Brown/White
W/R	White/Red
W/G	White/Green
W/Y	White/Yellow