

## CHAPTER 5. CHASSIS

<b>FRONT WHEEL</b> .....	5-1
REMOVAL .....	5-2
INSPECTION .....	5-2
INSTALLATION .....	5-4
<b>REAR WHEEL</b> .....	5-6
REMOVAL .....	5-7
INSPECTION .....	5-7
INSTALLATION .....	5-8
<b>FRONT AND REAR BRAKE</b> .....	5-9
CALIPER PAD REPLACEMENT .....	5-11
CALIPER DISASSEMBLY .....	5-12
MASTER CYLINDER DISASSEMBLY .....	5-13
BRAKE INSPECTION AND REPAIR .....	5-16
BRAKE REASSEMBLY .....	5-17
AIR BLEEDING .....	5-19
BRAKE DISC INSTALLATION .....	5-20
<b>FRONT FORK</b> .....	5-21
REMOVAL .....	5-22
DISASSEMBLY .....	5-23
INSPECTION .....	5-24
ASSEMBLY .....	5-25
INSTALLATION .....	5-26
<b>STEERING HEAD</b> .....	5-28
REMOVAL .....	5-29
INSPECTION .....	5-30
INSTALLATION .....	5-31
<b>REAR SHOCK ABSORBER</b> .....	5-33
HANDLING NOTES .....	5-34
NOTES ON DISPOSAL .....	5-34
REMOVAL .....	5-35
INSPECTION .....	5-35
INSTALLATION .....	5-35
<b>SWINGARM</b> .....	5-37
FREE PLAY INSPECTION .....	5-38
REMOVAL .....	5-38
INSPECTION .....	5-39
INSTALLATION .....	5-39
<b>DRIVE CHAIN AND SPROCKETS</b> .....	5-41
REMOVAL .....	5-41
INSPECTION .....	5-41
ASSEMBLY .....	5-42

**CHASSIS**

**FRONT WHEEL**

- ① Collar
- ② Oil seal
- ③ Bearing
- ④ Spacer
- ⑤ Spacer flange
- ⑥ Meter clutch
- ⑦ Clutch retainer
- ⑧ Oil seal
- ⑨ Gear unit

Basic weight: With oil and full fuel tank	SRX600S: 176 kg (388 lb) SRX600SC: 176.5 kg (389 lb)	
Maximum load*	SRX600S: 204 kg (450 lb) SRX600SC: 203.5 kg (449 lb)	
Cold tire pressure	Front	Rear
Up to 90 kg (198 lb) load*	177 kPa (1.8 kg/cm <sup>2</sup> , 26 psi)	196 kPa (2.0 kg/cm <sup>2</sup> , 28 psi)
90 kg (198 lb) ~ Maximum load*	196 kPa (2.0 kg/cm <sup>2</sup> , 28 psi)	226 kPa (2.3 kg/cm <sup>2</sup> , 32 psi)
High speed riding	196 kPa (2.0 kg/cm <sup>2</sup> , 28 psi)	226 kPa (2.3 kg/cm <sup>2</sup> , 32 psi)

\* Load is the total weight of cargo, rider, passenger, and accessories.

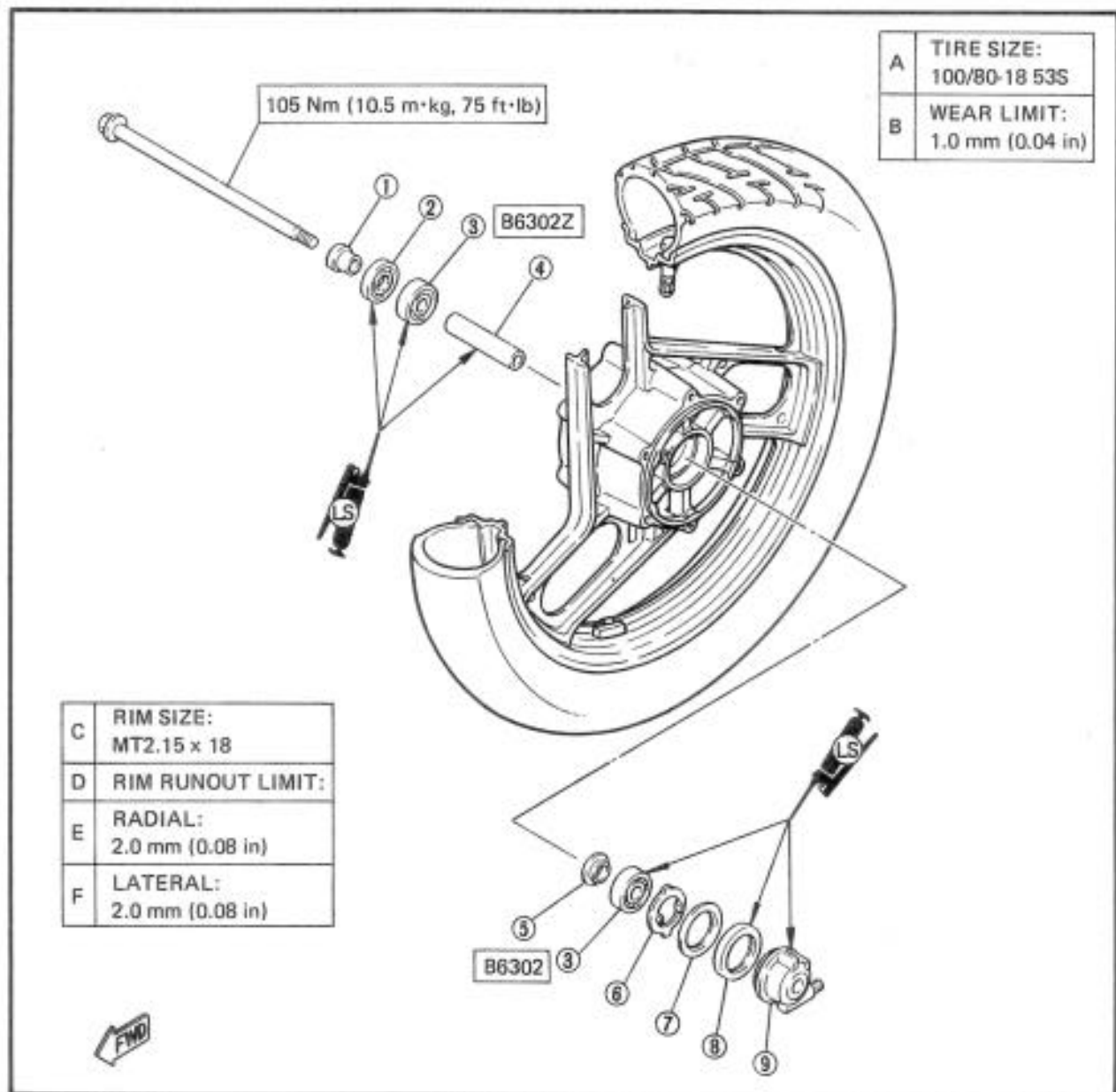

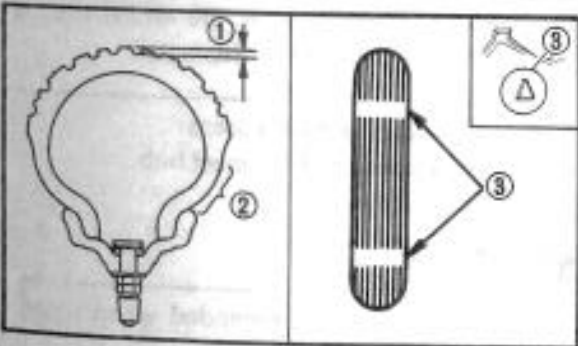
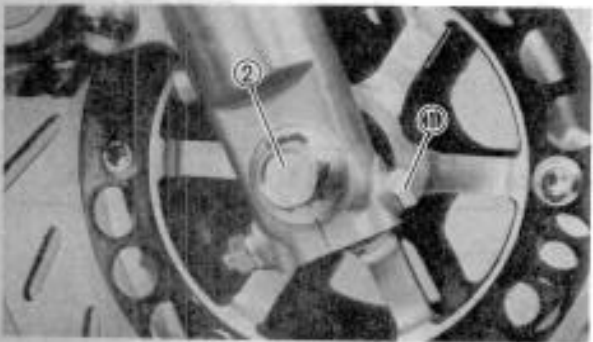
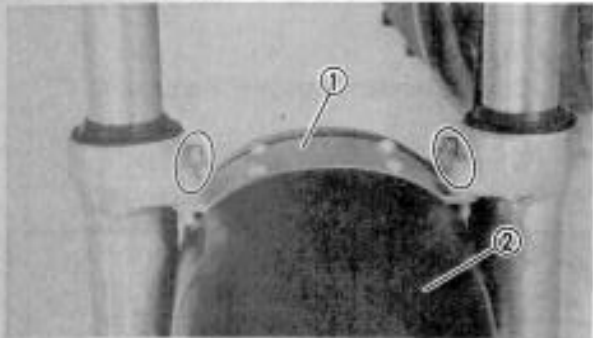

## REMOVAL

**WARNING:**

Securely support the motorcycle so it won't fall over when the front wheel.

1. Place the motorcycle on level place.
2. Remove:
  - Speedometer cable ①
3. Remove:
  - Fork brace ①
  - Front fender ②

4. Loosen:
  - Pinch bolt (Front axle) ①
  - Front axle ②
5. Elevate the front wheel by placing a suitable stand under the engine.
6. Remove:
  - Front axle
  - Front wheel

Lower the wheel until the brake discs come off the calipers. Turn the brake calipers outward so they do not obstruct the wheel.

**NOTE:**

Do not squeeze the brake lever while the wheel is off the motorcycle.

## INSPECTION

1. Inspect:
  - Tire

Tire tread shows crosswise lines (Minimum tread depth)/Cracks → Replace.



**Minimum Tire Tread Depth:**  
1.0 mm (0.04 in)

- ① Tread depth    ② Sidewall    ③ Wear indicator

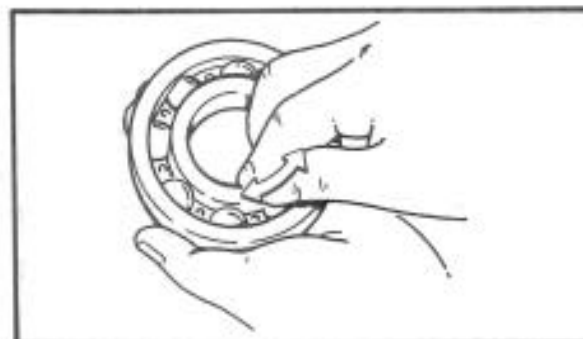
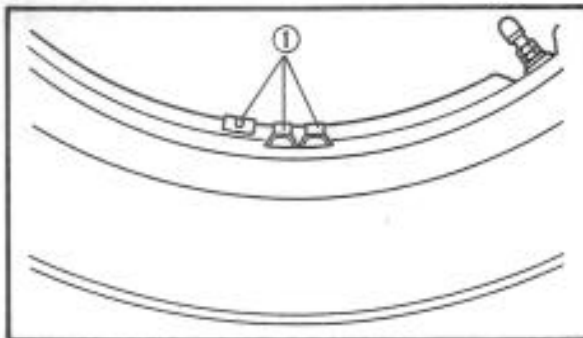
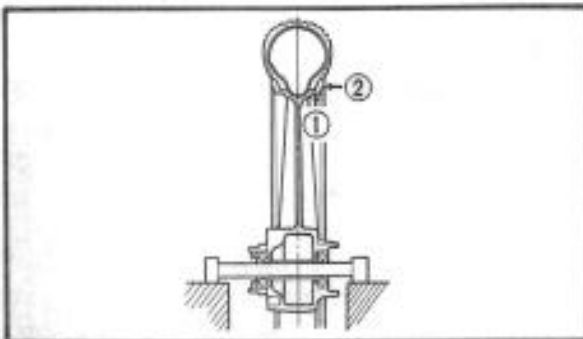
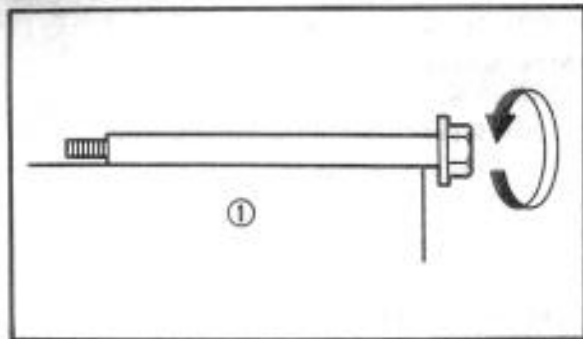

2. Inspect:
  - Front axle
    - Bends → Replace.
    - Roll the axle on a flat surface ①.

**WARNING:**

Do not attempt to straighten a bent axle.

3. Inspect:
  - Wheel
    - Cracks/Bends/Warpage → Replace.
4. Measure:
  - Wheel runout
    - Out of specification → Replace.

**Rim Runout Limits:**

Raidal ① : 2.0 mm (0.08 in)

Lateral ② : 2.0 mm (0.08 in)

5. Check:
  - Wheel balance
    - Out of balance → Adjust.

**NOTE:**

Balance wheels with the brake discs installed.

- ① Balancer weight

**CAUTION:**

Be sure the valve stem locknut is tightened securely after repairing or replacing a tire and/or wheel.

**WARNING:**

Ride conservatively after installing a tire to allow the tire to seat itself correctly on the rim.

6. Inspect:
  - Wheel bearings
    - Bearings allow play in the wheel hub or wheel turns roughly → Replace.

**Wheel bearing replacement steps:**

- Clean the outside of the wheel hub.
- Drive out the bearing.

**WARNING:**

Eye protection is recommended when using striking tools.

## FRONT WHEEL

## REMOVAL

## 1. Remove the front wheel.

## 2. Remove the front wheel nut.

## 3. Remove the front wheel disc.

## 4. Remove the front wheel hub.

## 5. Remove the front wheel bearings.

## 6. Remove the front wheel axle.

## 7. Remove the front wheel.

## 8. Remove the front wheel.

## 9. Remove the front wheel.

## 10. Remove the front wheel.

## 11. Remove the front wheel.

## 12. Remove the front wheel.

## 13. Remove the front wheel.

## 14. Remove the front wheel.

## 15. Remove the front wheel.

## 16. Remove the front wheel.

## 17. Remove the front wheel.

## 18. Remove the front wheel.

## 19. Remove the front wheel.

## 20. Remove the front wheel.

## 21. Remove the front wheel.

## 22. Remove the front wheel.

## 23. Remove the front wheel.

## 24. Remove the front wheel.

## 25. Remove the front wheel.

## 26. Remove the front wheel.

## 27. Remove the front wheel.

## 28. Remove the front wheel.

## 29. Remove the front wheel.

## 30. Remove the front wheel.

## 31. Remove the front wheel.

## 32. Remove the front wheel.

## 33. Remove the front wheel.

## 34. Remove the front wheel.

## 35. Remove the front wheel.

## 36. Remove the front wheel.

## 37. Remove the front wheel.

## 38. Remove the front wheel.

## 39. Remove the front wheel.

## 40. Remove the front wheel.

- Install the new bearing by reversing the previous steps.

**CAUTION:**

Do not strike the center race or balls of the bearing. Contact should be made only with the outer race.

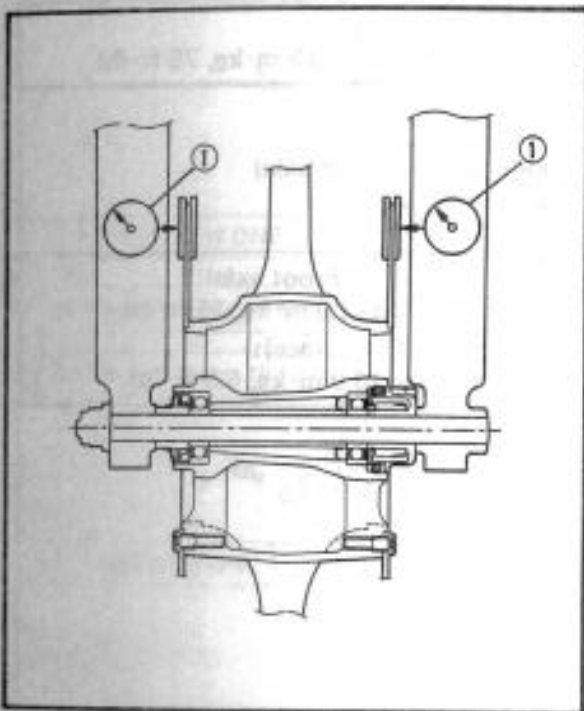

## 7. Inspect:

- Brake disc

Out of specification → Replace.

**Maximum Deflection**

(Front and Rear):

0.15 mm (0.006 in)

**Minimum Disc Thickness**

(Front and Rear):

4.5 mm (0.18 in)

① Dial gauge

**INSTALLATION**

When installing the front wheel, reverse the removal procedure. Note the following points.

## 1. Apply:

- Lithium base grease

Lightly grease to the oil seal and gear unit.

## 2. Install:

- Gear unit assembly

**NOTE:**

Be sure that the two projections inside the wheel hub mesh with the two slots in the gear unit assembly.

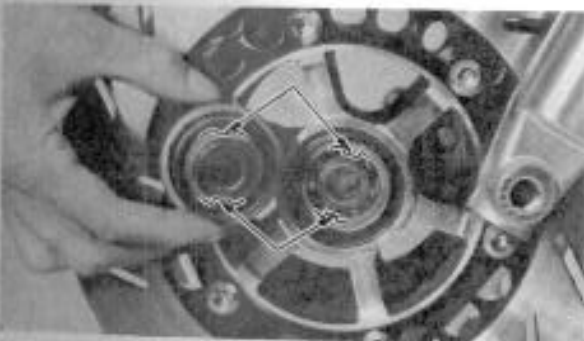

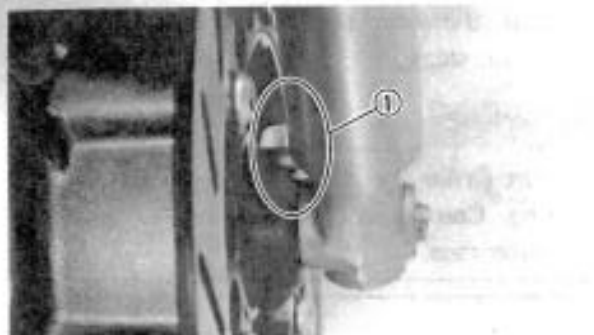

3. Install:
- Front wheel

**NOTE:**

Be sure that the projecting portion (Torque stopper) ① of the gear unit housing is positioned correctly.

4. Tighten:
- Front axle



**Front Axle:**  
105 Nm (10.5 m·kg, 75 ft·lb)

5. Tighten:
- Pinch bolt (Front axle)
  - Fork brace



**Pinch Bolt (Front axle):**  
20 Nm (2.0 m·kg, 14 ft·lb)  
**Bolts (Fork brace):**  
9 Nm (0.9 m·kg, 6.5 ft·lb)

REAR WHEEL

- ① Indicator plate
- ② Drive chain puller
- ③ Collar
- ④ Oil seal
- ⑤ Bearing
- ⑥ Spacer flange
- ⑦ Spacer
- ⑧ Damper
- ⑨ Clutch hub
- ⑩ Driven sprocket
- ⑪ Collar
- ⑫ Drive chain
- ⑬ Tension bar

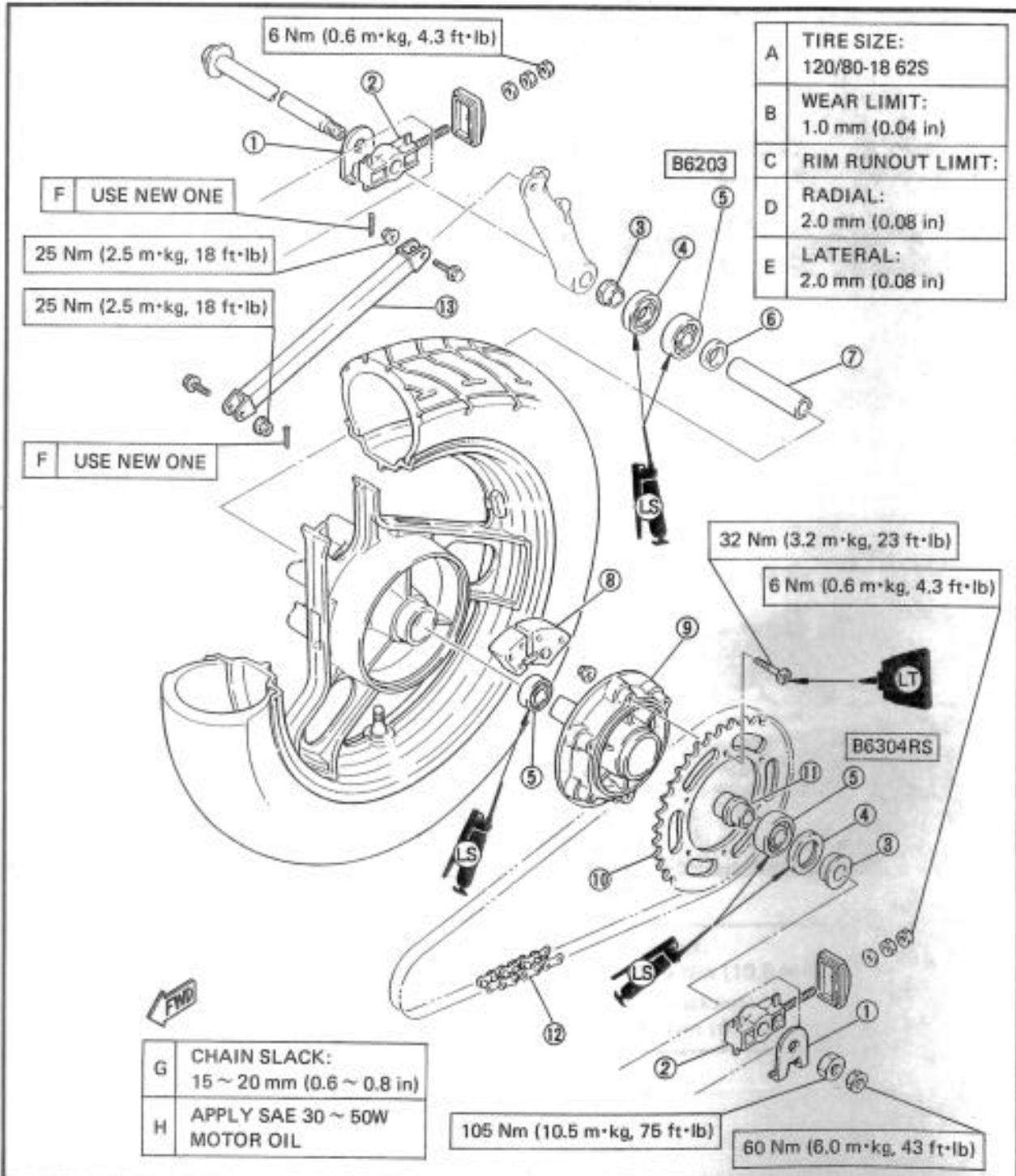

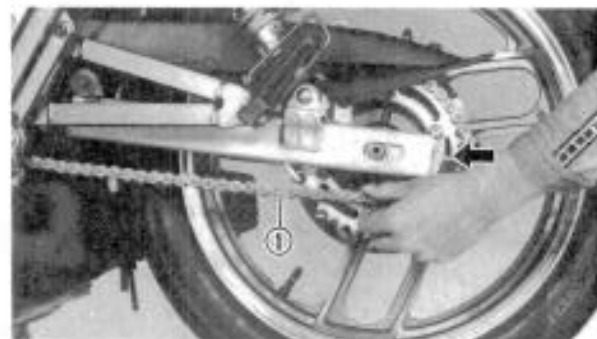
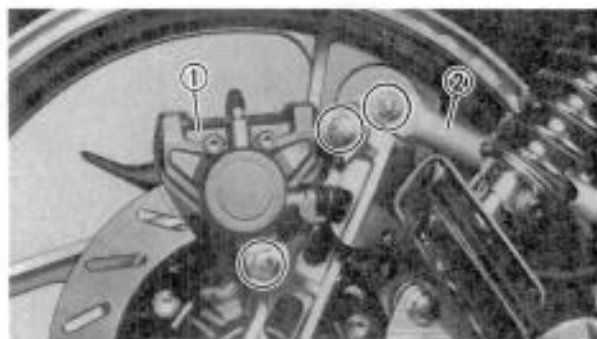
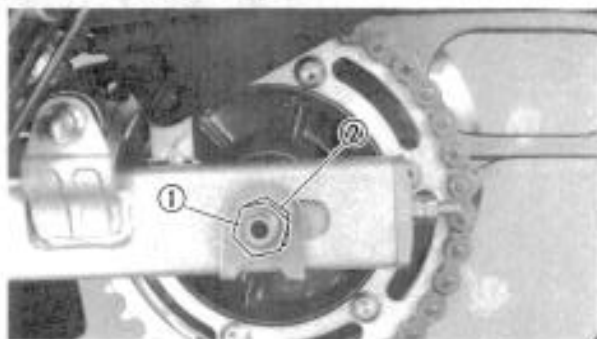
**REMOVAL**

1. Place the motorcycle on level place.
2. Remove:
  - Axle locknut ①
  - Axle nut ②
3. Remove:
  - Rear caliper ①
  - Tension bar ②

4. Elevate the rear wheel by placing a suitable stand.
5. Remove:
  - Rear axle

**NOTE:**

- Before removing the rear axle, loosen the chain pullers (Left and right).
- While supporting the brake caliper, pull out the rear axle.

6. Push the wheel forward and remove the drive chain ①.

7. Remove:
  - Rear wheel

**NOTE:**

Do not depress the brake pedal when the wheel is off the motorcycle as the brake pads will be forced shut.

**INSPECTION**

1. Inspect:
  - Tire
  - Rear axle
  - Wheel
  - Wheel bearings
  - Brake discRefer to "FRONT WHEEL – INSPECTION" section.



## 2. Measure:

- Wheel runout

Refer to "FRONT WHEEL – INSPECTION" section.

## 3. Check:

- Wheel balance

Refer to "FRONT WHEEL – INSPECTION" section.

**INSTALLATION**

When installing the rear wheel, reverse the removal procedure. Note the following points.

## 1. Apply:

- Lithium base grease

Lightly grease to the oil seals and bearings.

## 2. Adjust:

- Drive chain slack

Refer to "CHAPTER 2. DRIVE CHAIN SLACK ADJUSTMENT" section.



**Drive Chain Slack:**

15 ~ 20 mm (0.6 ~ 0.8 in)

## 3. Install:

- Tension bar
- Rear caliper



**Tension Bar:**

25 Nm (2.5 m·kg, 18 ft·lb)

**Rear Caliper:**

35 Nm (3.5 m·kg, 25 ft·lb)

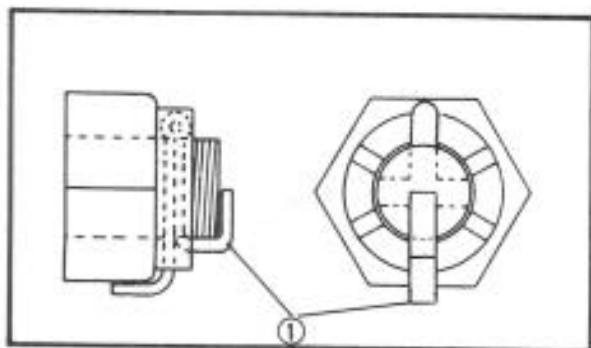
**CAUTION:**

Always use new cotter pins ① on the tension bar bolts.

## 4. Tighten:

- Axle nut
- Axle locknut



**Axle Nut:**

105 Nm (10.5 m·kg, 75 ft·lb)

**Axle Locknut:**

60 Nm (6.0 m·kg, 43 ft·lb)

**FRONT AND REAR BRAKE**

- ① Air bleed screw
- ② Retaining pin
- ③ Dust seal
- ④ Piston seal
- ⑤ Piston
- ⑥ Shim

- F - ①: Install the pad spring with its round side (a) facing towards the disc rotating direction.
- G - ①: Be sure to position the shim (1) so that its top hook (a) points in the rotating direction (b) of the disc plate rotation.

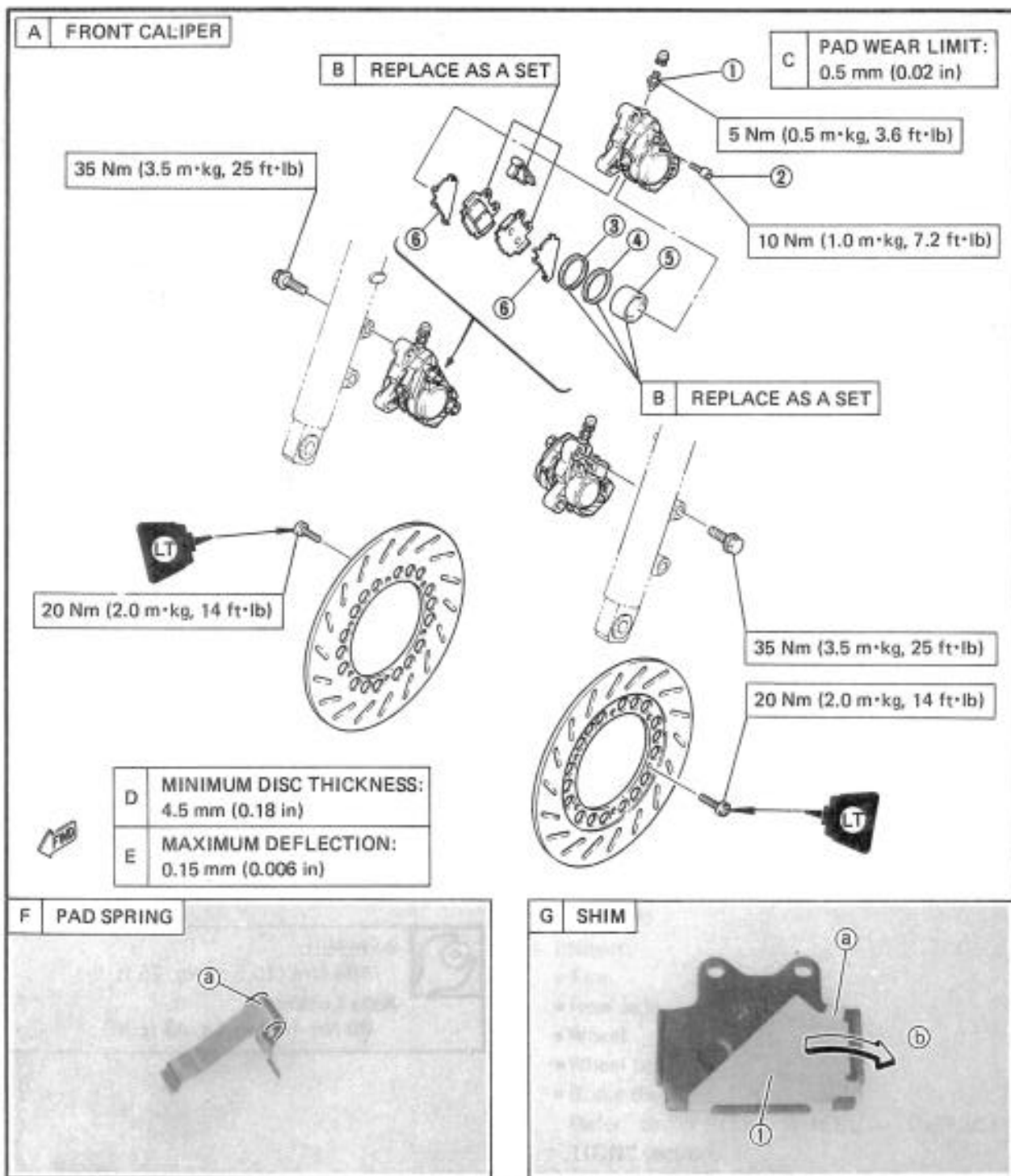

- ① Air bleed screw
- ② Retaining pin
- ③ Dust seal
- ④ Piston seal
- ⑤ Piston

F - a: Install the pad spring with its round side (a) facing towards the disc rotating direction.

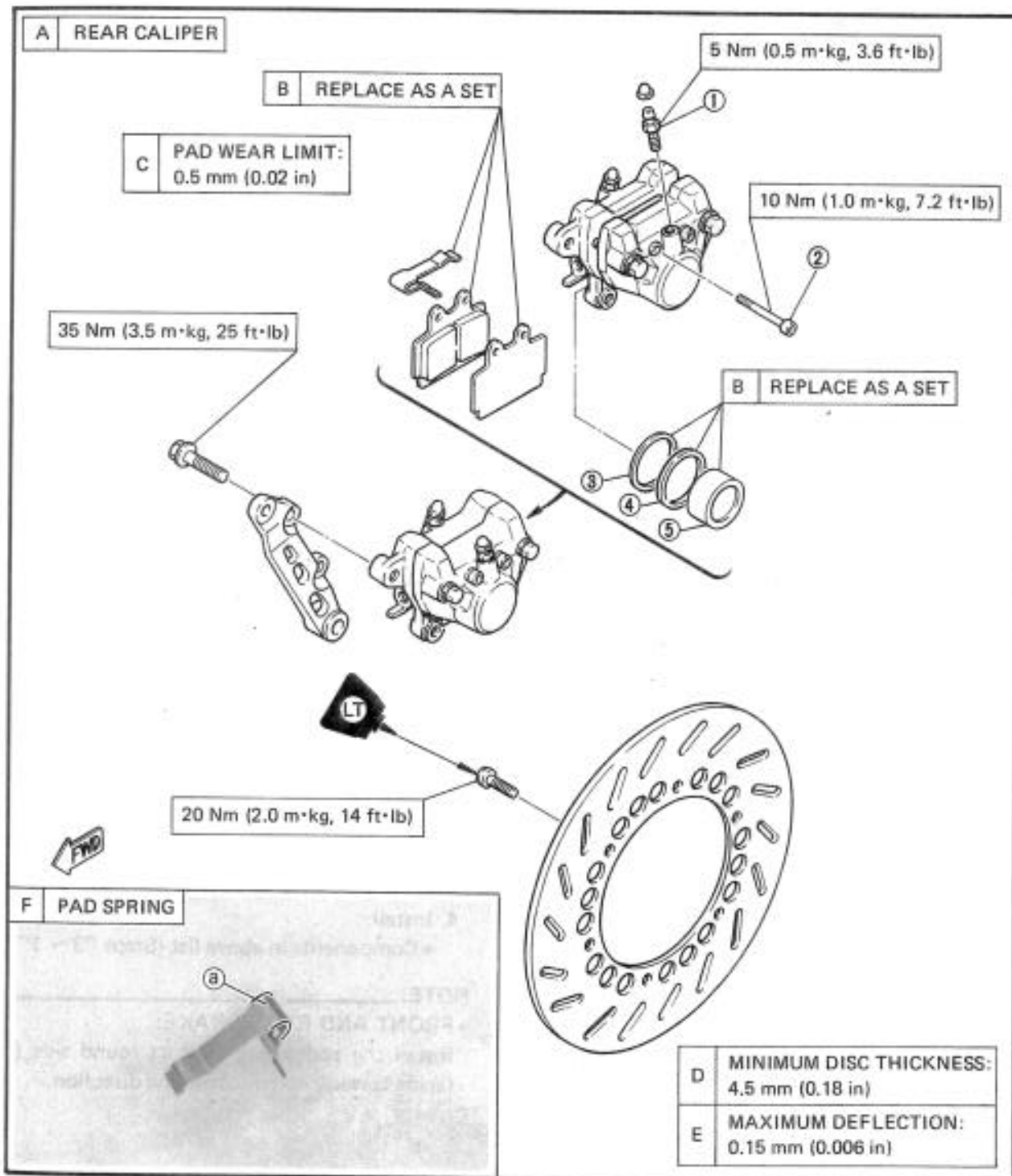

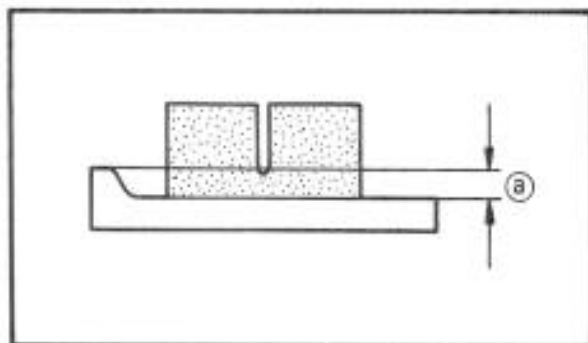
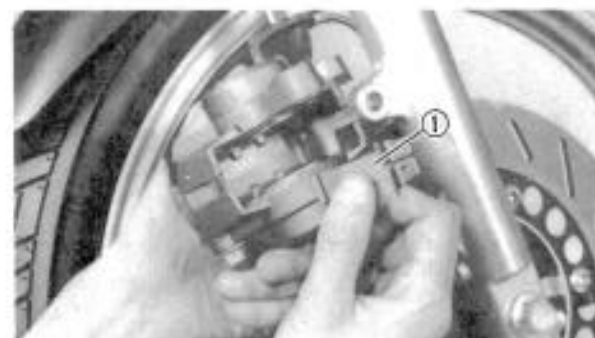
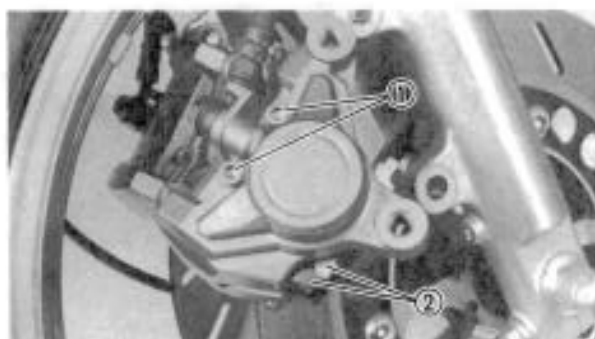

### CALIPER PAD REPLACEMENT

It is not necessary to disassemble the brake hose to replace the brake pads.

1. Remove:

- Caliper ①

2. Remove:

- Retaining pins ①
- Pads ②

3. Remove:

- Pad spring ①

NOTE:

- Replace the pad spring if pad replacement is required.
- Replace the pads as a set if either is found to be worn to the wear limit.



Wear Limit (a) :  
0.5 mm (0.02 in)

4. Install:

- Components in above list (Steps "3 ~ 1")

NOTE:

• FRONT AND REAR BRAKE:

- Install the pad spring with its round side (a) facing towards the disc rotating direction.

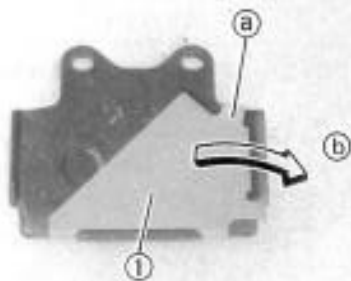

• FRONT BRAKE ONLY:

Be sure to position the shim ① so that its top hook ② points in the rotating direction ③ of the disc plate rotation.

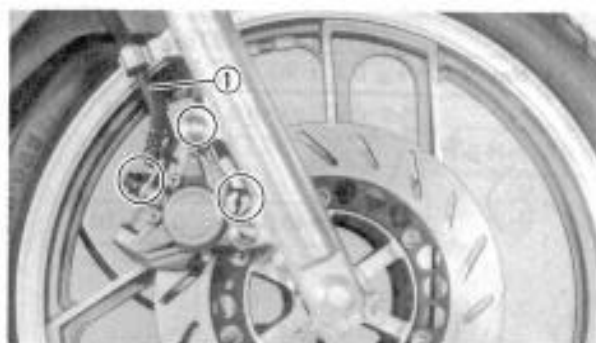

**CALIPER DISASSEMBLY**

1. Remove:

- Brake hose ①  
Place the open hose end into a container and pump the old fluid out carefully.
- Pads  
Refer to "CALIPER PAD REPLACEMENT" section.



2. Remove:

- Caliper

**CAUTION:**

Never loosen the bridge bolts ① on either side of the caliper.

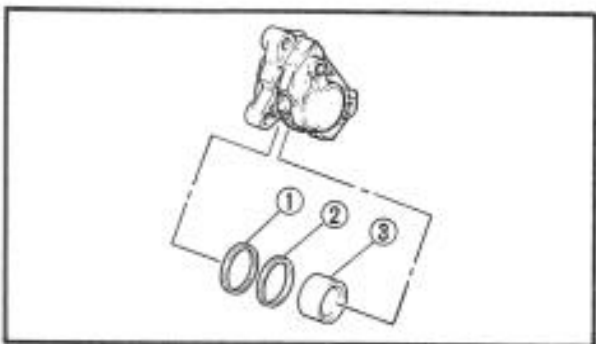

3. Remove:

- Dust seals ①
- Piston seals ②
- Pistons ③

**Caliper piston removal steps:**

- Insert a piece of wooden board ④ into the caliper to lock the right side piston.
- Blow compressed air into the tube joint opening to force out the left side piston from the caliper body.
- Repeat previous step to force out the right side piston from the caliper body.

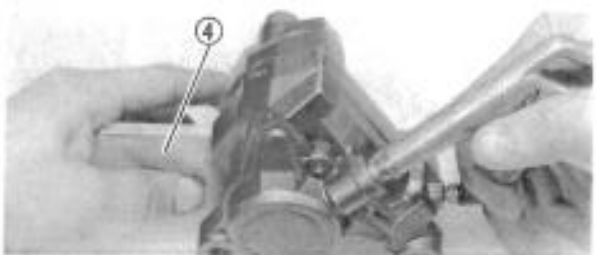

**MASTER CYLINDER DISASSEMBLY**

- ① Master cylinder cap
- ② Rubber seal
- ③ Master cylinder kit
- ④ Copper washer
- ⑤ Brake joint

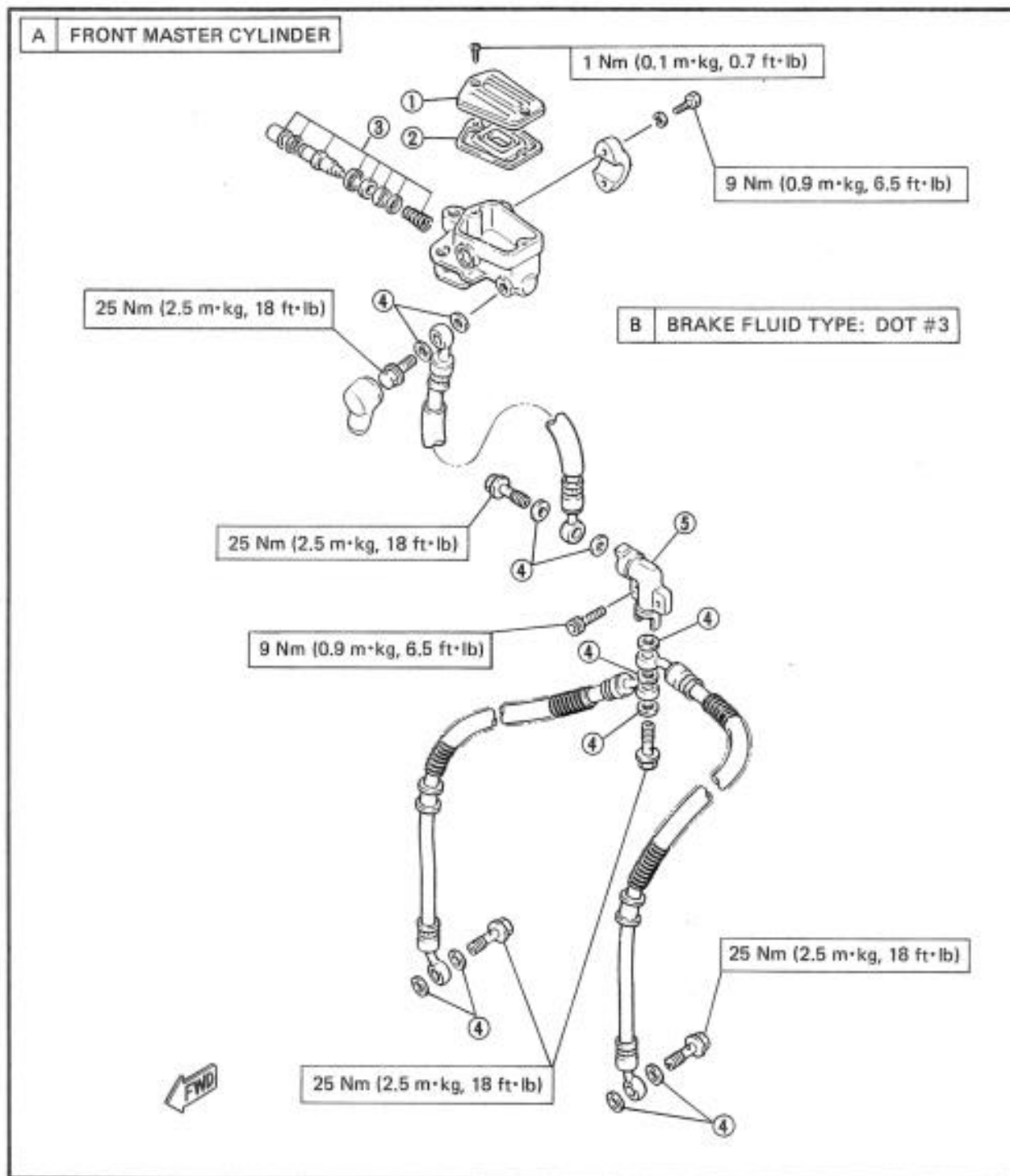

- ① Reservoir tank
- ② Band
- ③ Copper washer
- ④ Master cylinder kit

- ① BRAKE HOSE ROUTING:  
When installing the rear brake hose, lightly touch the brake pipe ① with the projection ② on the master cylinder.

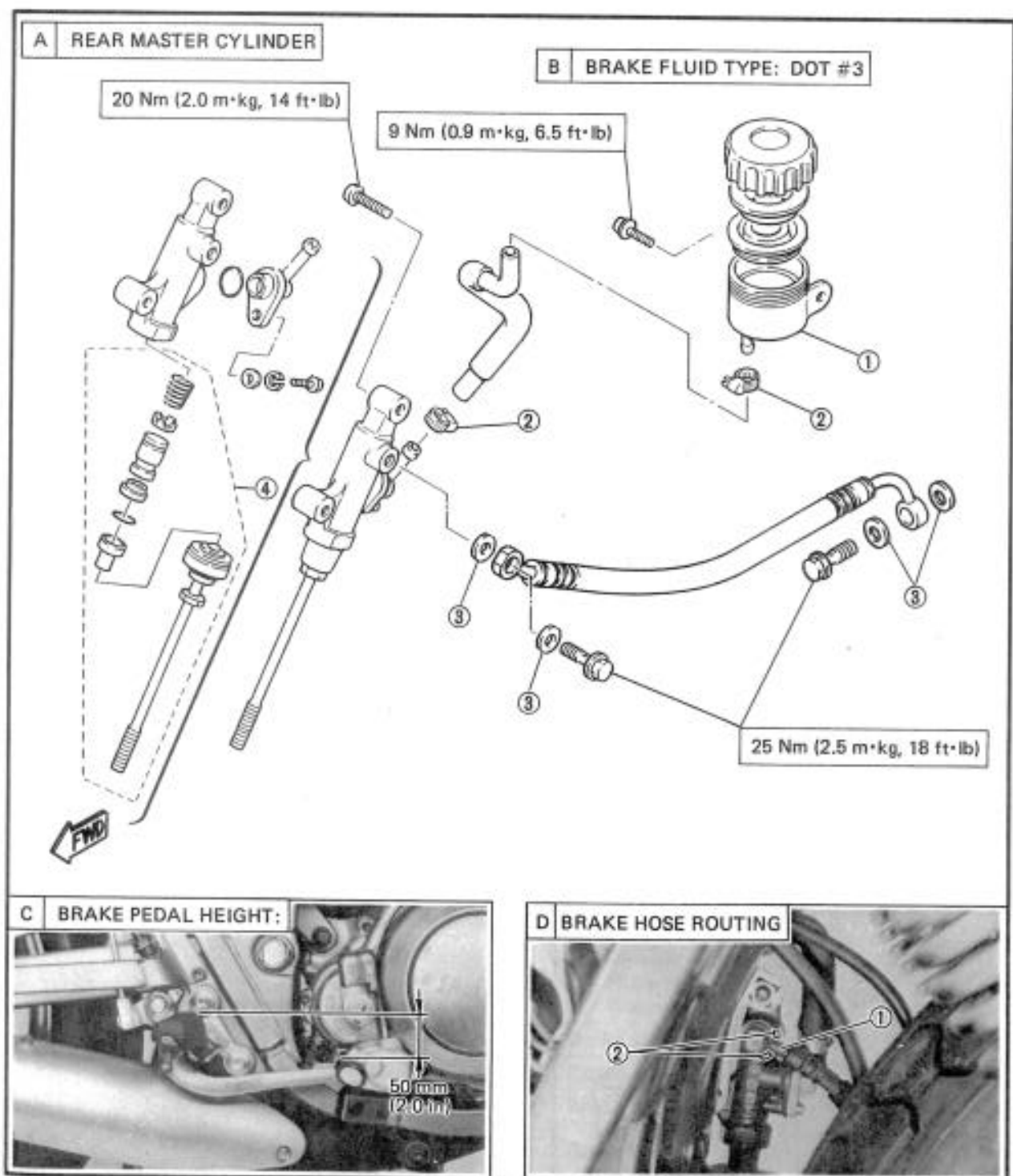

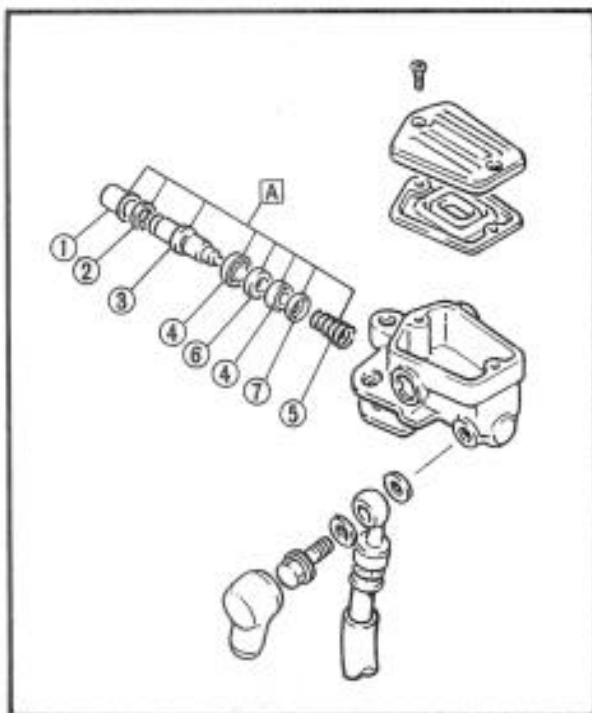

### Front Brake Master Cylinder Disassembly

#### NOTE:

Drain the brake fluid before removing master cylinder.

- ① Dust boot
- ② Circlip
- ③ Piston
- ④ Piston cups
- ⑤ Return spring
- ⑥ Washer
- ⑦ Seat

**A** MASTER CYLINDER KIT (Replace as a set)

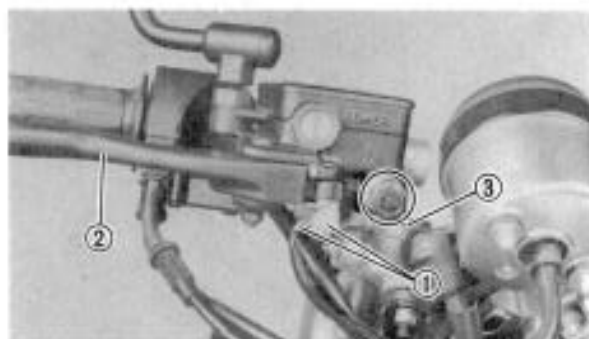

1. Remove:
  - Brake light switch leads ①
  - Brake lever ②
  - Lever spring
2. Disconnect:
  - Brake hose ③
 Drain the fluid.



3. Remove:
  - Master cylinder ①
  - Master cylinder cap ②

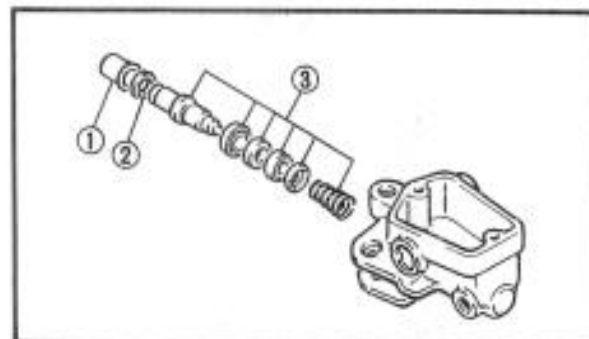

4. Remove:
  - Dust boot ①
  - Circlip ②
  - Master cylinder kit ③



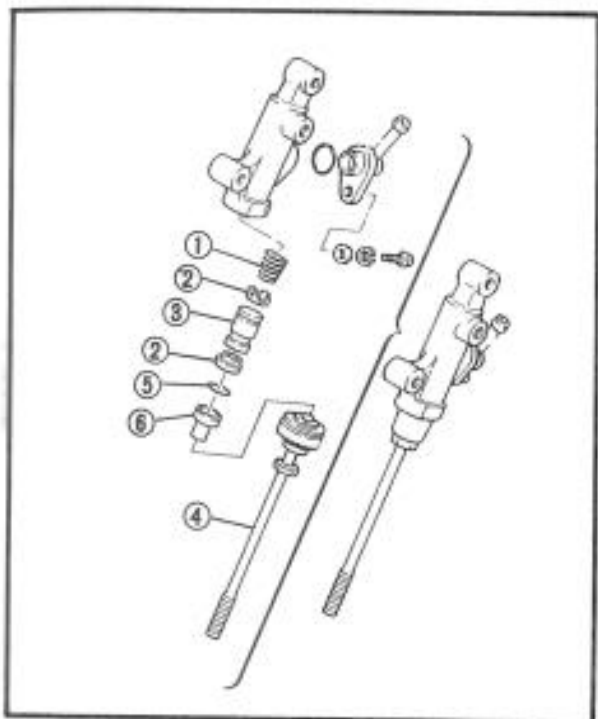

Rear Brake Master Cylinder Disassembly

NOTE:

Drain the brake fluid before removing master cylinder.

1. Remove:
  - Side cover (Right)
2. Disconnect:
  - Brake hose

- ① Spring
- ② Piston cup
- ③ Piston
- ④ Adjusting rod
- ⑤ Circlip
- ⑥ Dust boot
- Ⓐ MASTER CYLINDER KIT (Replace as a set)

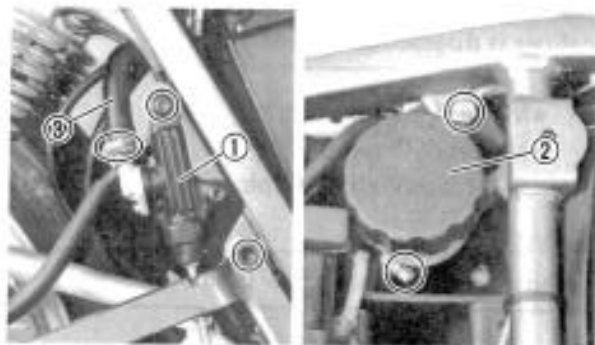

3. Remove:
  - Master cylinder ①
  - Fluid reservoir tank ②  
Drain the fluid.
4. Disconnect:
  - Tank hose ③

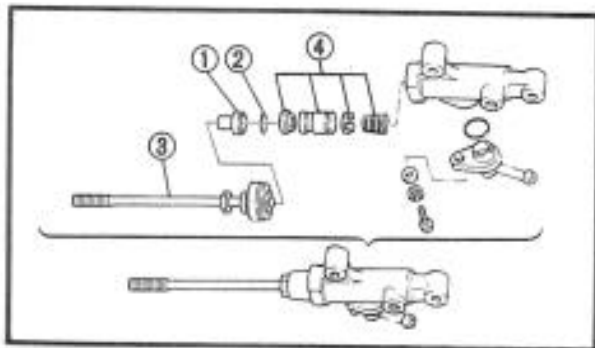

5. Remove:
  - Dust boot ①
  - Circlip ②
  - Adjusting rod ③
  - Master cylinder kit ④  
Drain the excess fluid.

BRAKE INSPECTION AND REPAIR

Recommended Brake Component Replacement Schedule:	
Brake pads	As required
Piston seal, dust seal	Every two years
Brake hoses	Every four years
Brake fluid	Replace only when brakes are disassembled

**WARNING:**

All internal parts should be cleaned in new brake fluid only. Do not use solvents will cause seals to swell and distort.

## 1. Inspect:

- Brake pads

Over specified limit → Replace.

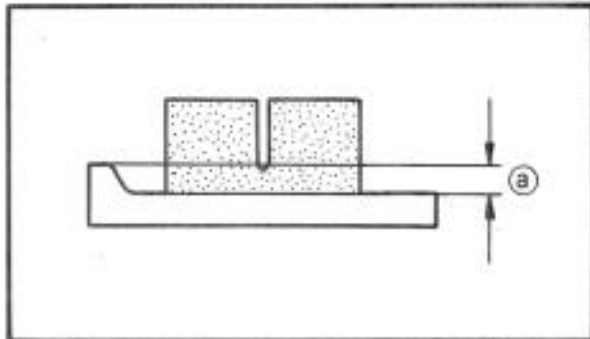

Wear Limit (a) :  
0.5 mm (0.02 in)

## 2. Inspect:

- Caliper piston  
Rust/Wear/Damage → Replace.
- Dust seal/Piston seal  
Damage → Replace.

**WARNING:**

Replace the piston and dust seals whenever a caliper is disassembled.

- Master cylinder kit
- Master cylinder body  
Scratches/Wear → Replace.

**NOTE:**

Clean all passages with new brake fluid.

- Brake hose  
Cracks/Wear/Damage → Replace.

**BRAKE REASSEMBLY****WARNING:**

- All internal parts should be cleaned in new brake fluid only.
- Internal parts should be lubricated with brake fluid when installed.



Brake Fluid:  
DOT #3

**Caliper Reassembly**

When assembling the caliper, reverse the disassembly procedure. Note the following points.

1. Install:
  - Brake calipers
  - Brake hoses



**Brake Caliper:**  
35 Nm (3.5 m·kg, 25 ft·lb)

**Brake Hose:**  
25 Nm (2.5 m·kg, 18 ft·lb)

2. Bleed the air completely from the brake system.

**Master Cylinder Reassembly**

When assembling the master cylinder, reverse the disassembly procedure. Note the following points.

1. Install:
  - Master cylinder kit

**WARNING:**

Internal parts should be lubricated with brake fluid when installed.

2. Install:
  - Master cylinders (Front and rear)
  - Brake hoses



**Front Master Cylinder:**  
9 Nm (0.9 m·kg, 6.5 ft·lb)

**Rear Master Cylinder:**  
20 Nm (2.0 m·kg, 14 ft·lb)

**Brake Hose:**  
25 Nm (2.5 m·kg, 18 ft·lb)

**CAUTION:**

When installing the rear brake hose, lightly touch the brake pipe ① with the projection ② on the master cylinder.

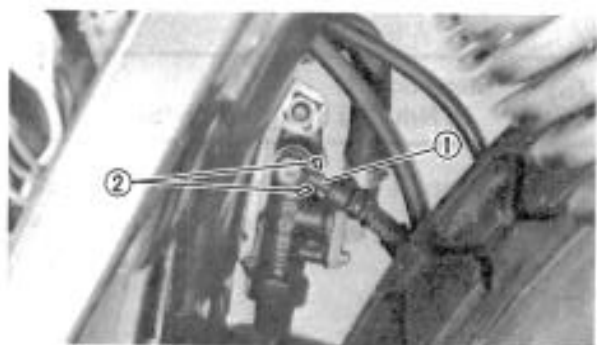



## 3. Fill:

- Master cylinders



Brake Fluid:  
DOT #3

4. Bleed the air completely from the brake system.

## AIR BLEEDING

**WARNING:**

Bleed the brake system if:

- The system has been disassembled.
- A brake hose has been loosened or removed.
- The brake fluid is very low.
- The brake operation is faulty.

A dangerous loss of braking performance may occur if the brake system is not properly bled.



## 1. Bleed:

- Brake fluid

**Air bleeding steps:**

- Add proper brake fluid to the reservoir.
- Install the diaphragm. Be careful not to spill any fluid or allow the reservoir to overflow.
- Connect the clear plastic tube ① tightly to the caliper bleed screw.
- Place the other end of the tube into a container.
- Slowly apply the brake lever or pedal several times.
- Pull the lever in or push down on the pedal. Hold the lever or pedal in position.
- Loosen the bleed screw and allow the lever or pedal to travel towards its limit.
- Tighten the bleed screw when the lever or pedal limit has been reached; then release the lever or pedal.



Bleed Screw:  
5 Nm (0.5 m·kg, 3.6 ft·lb)

- Repeat steps (e) to (h) until of the air bubbles have been removed from the system.

**NOTE:**

If bleeding is difficult, it may be necessary to let the brake fluid system stabilize for a few hours. Repeat the bleeding procedure when the tiny bubbles in the system have disappeared.

- j. Add brake fluid to the level line on the reservoir.

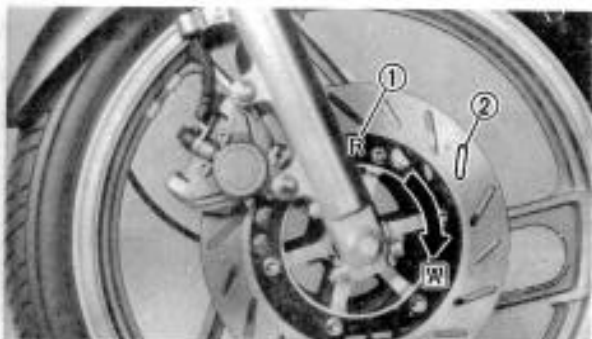
**BRAKE DISC INSTALLATION****1. Install:**

- Brake disc(s)

**NOTE:****FRONT BRAKE ONLY:**

- The brake disc should be installed with the identified mark (L or R) ① face outward.

**FRONT AND REAR BRAKE:**

- The slots ② in the disc must point in the rotating direction **A** of the wheel.

**2. Tighten:**

- Bolts (Disc)

**Bolts:**

20 Nm (2.0 m·kg, 14 ft·lb)  
LOCTITE®

**FRONT FORK**

- ① Fork cap
- ② O-ring
- ③ Cap bolt
- ④ Collar
- ⑤ Spring seat
- ⑥ Fork spring
- ⑦ Rebound spring
- ⑧ Cylinder complete
- ⑨ Oil lock piece
- ⑩ Inner fork tube
- ⑪ Guide bush
- ⑫ Dust cover
- ⑬ Retaining clip
- ⑭ Oil seal
- ⑮ Seal spacer
- ⑯ Slide bush
- ⑰ Outer fork tube
- ⑱ Drain screw

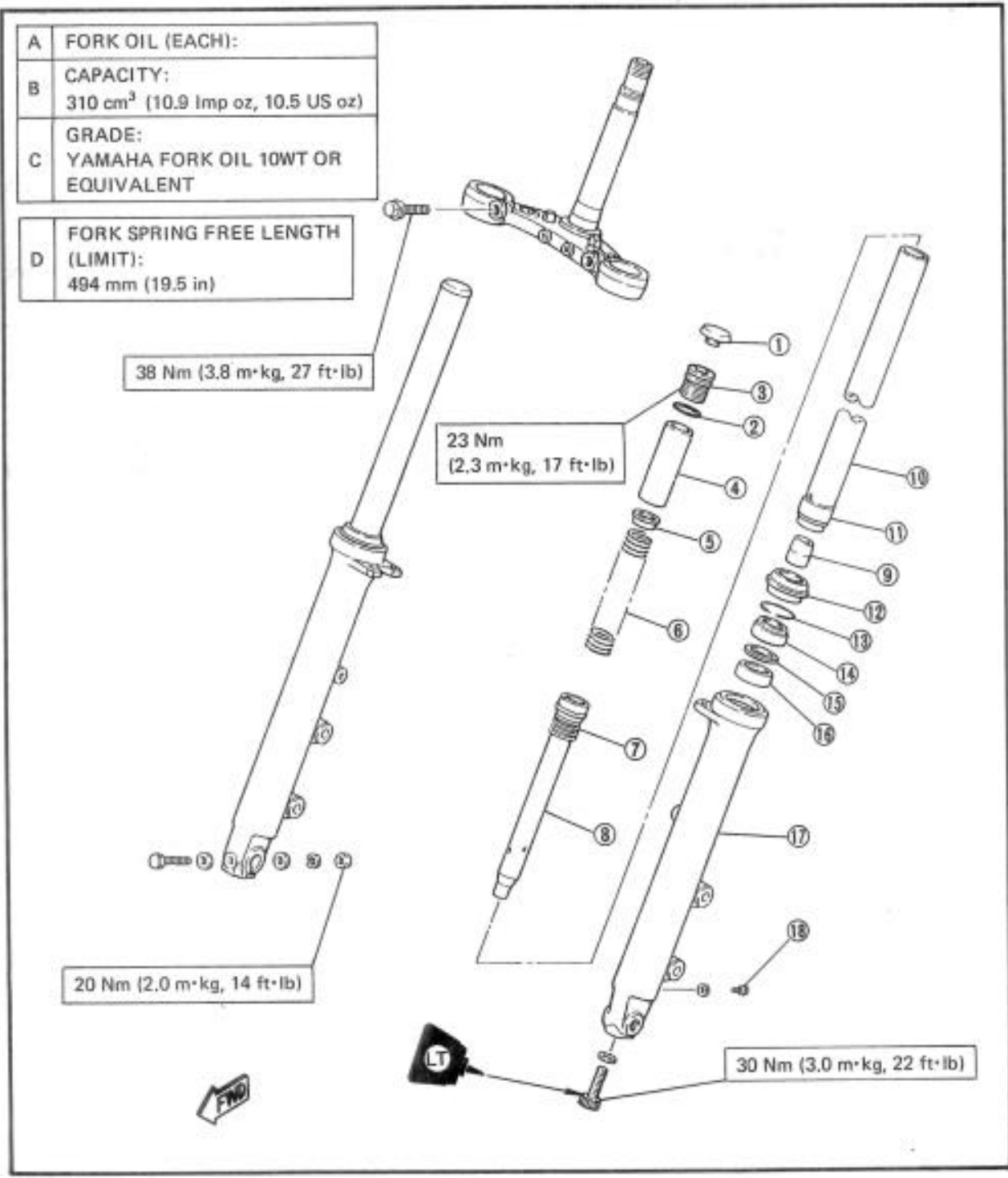

## REMOVAL

**WARNING:**

Securely support the motorcycle so it won't fall over when the front wheel and front forks are removed.

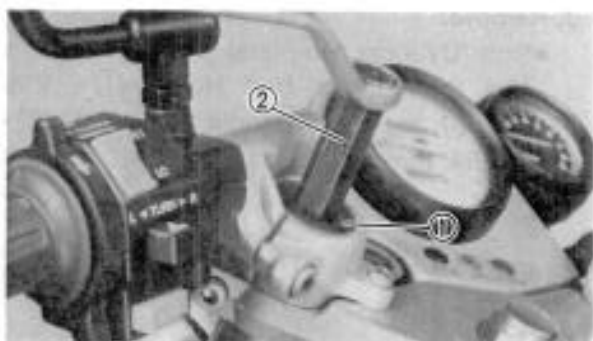
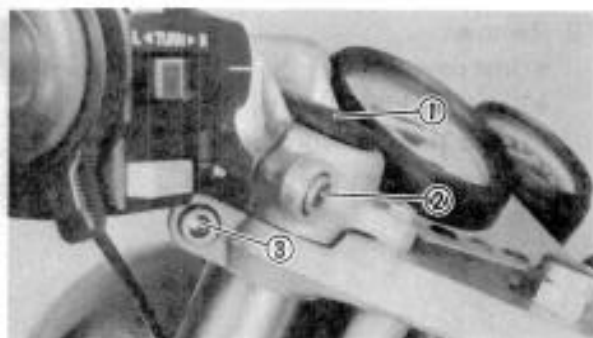

1. Remove:
  - Front wheel  
Refer to "FRONT WHEEL" section.
  - Brake calipers
2. Remove:
  - Fork cap ①
3. Loosen:
  - Pinch bolts (Handlebar) ②
  - Pinch bolts (Steering crown) ③
4. Loosen:
  - Cap bolt ①  
Use the Front Fork Cap Socket ② (90890-01104).
5. Loosen:
  - Pinch bolts (Under bracket) ①
6. Remove:
  - Front fork(s) ①

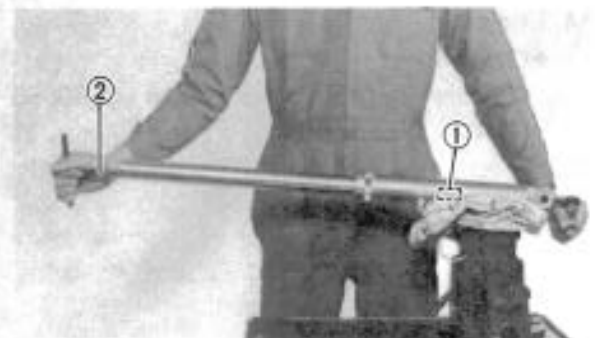
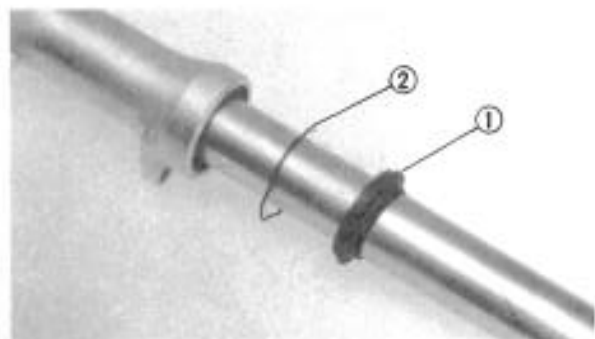
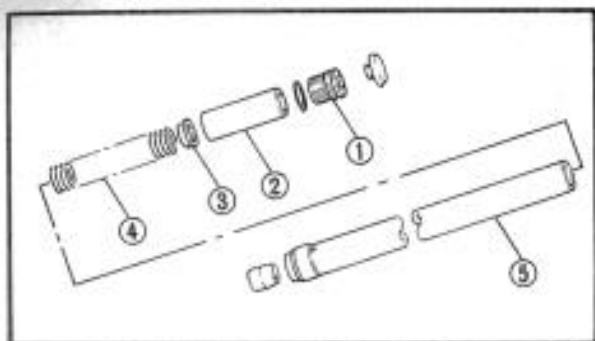

## DISASSEMBLY

## 1. Remove:

- Cap bolt ①  
Use the Front Fork Cap Socket (YM-01104).
- Collar ②
- Spring seat ③
- Fork spring ④  
Drain the fork oil.

## ⑤ Inner fork tube

## 2. Remove:

- Dust cover ①
- Retaining clip ②  
Use a thin screwdriver, and be careful not to scratch the inner fork tube.

## 3. Remove:

- Bolt (Cylinder complete)  
Use the Damper Rod Holder ① (YM-33298) and the T-Handle ② (YM-01326) to lock the damper rod.

## 4. Remove:

- Damper rod (Cylinder complete) ①
- Rebound spring ②

## 5. Remove:

- Inner fork tube

**Inner fork tube removal steps:**

- Hold fork leg horizontally.
- Clamp the caliper mounting boss of the outer tube securely in a vise with soft jaws.
- Pull out the inner fork tube from the outer tube by forcefully, but carefully, with drawing the inner tube.

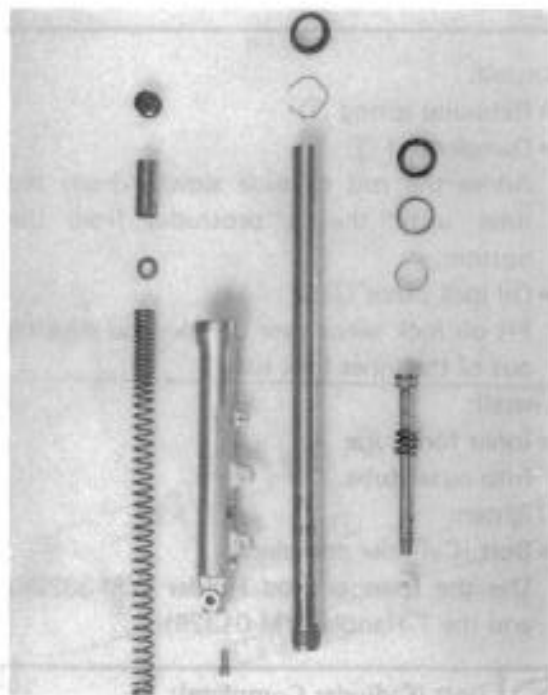
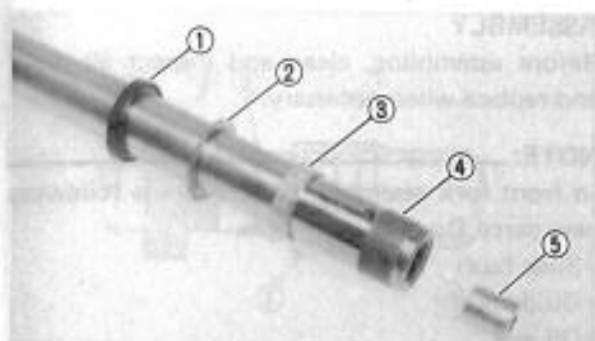

**NOTE:**

- Excessive force will damage the oil seal and/or the bushes. Damaged oil seal and bushing must be replaced.
- Avoid bottoming the inner tube in the outer tube during the above procedure, as the oil lock piece will be damaged.

**6. Remove:**

- Oil seal ①
- Seal spacer ②
- Slide bush ③
- Guide bush ④
- Oil lock piece ⑤

**INSPECTION****1. Inspect:**

- Inner fork tube  
Scratches/Bends → Replace.

**WARNING:**

Do not attempt to straighten a bent inner fork tube as this may dangerously weaken the tube.

- Outer fork tube  
Scratches/Bends/Damage → Replace.
- Fork spring  
Over specified limit → Replace.



**Fork Spring Free Length (Limit):**  
494 mm (19.5 in)

**2. Inspect:**

- Damper rod  
Wear/Damage → Replace.  
Contamination → Blow out all oil passages with compressed air.



## 3. Inspect:

- O-ring (Cap bolt) ①
- Oil lock piece ②  
Damage → Replace.
- Seals  
Wear/Damage → Replace.

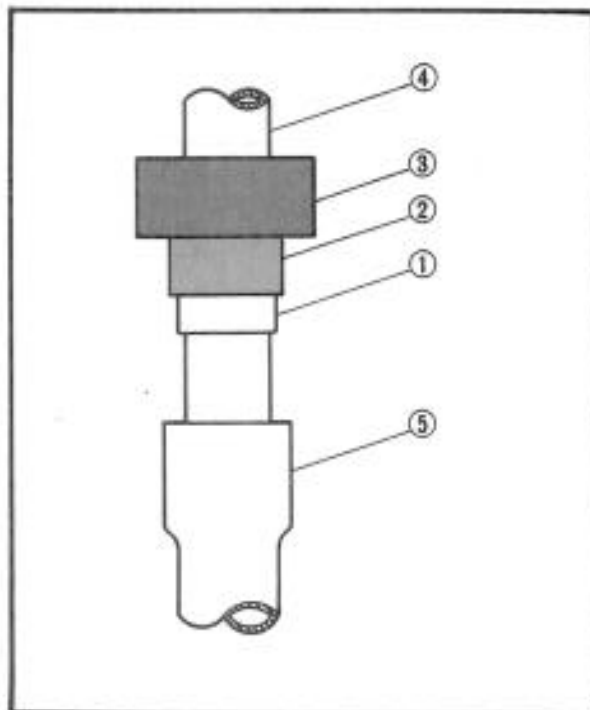
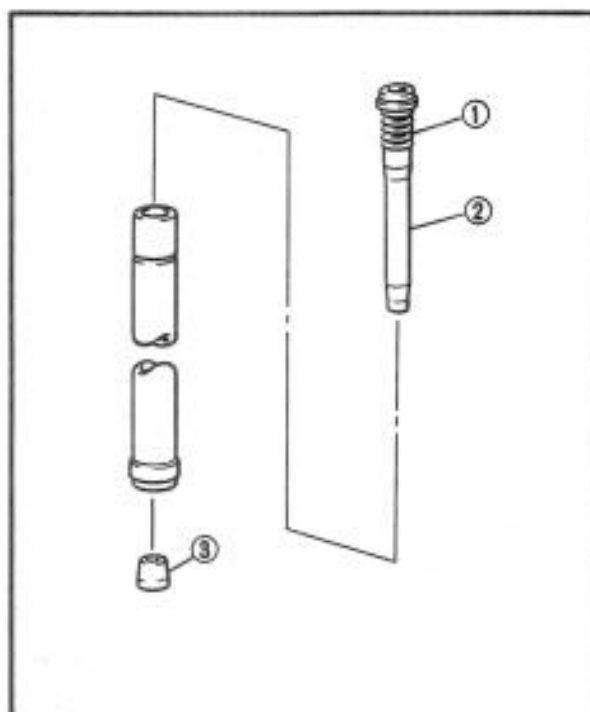
**ASSEMBLY**

Before assembling, clean and inspect all parts and replace when necessary.

**NOTE:**

In front fork assembly, be sure to use following new parts. Do not reuse them.

- Slide bush
- Guide bush
- Oil seal
- Dust seal

## 1. Install:

- Rebound spring ①
- Damper rod ②

Allow the rod to slide slowly down the tube until it protrudes from the bottom.

- Oil lock piece ③

Fit oil lock piece over damper rod sticking out of the inner fork tube.

## 2. Install:

- Inner fork tube  
Into outer tube.

## 3. Tighten:

- Bolt (Cylinder complete)

Use the Damper Rod Holder (YM-33298) and the T-Handle (YM-01326).



**Bolt (Cylinder Complete):**  
30 Nm (3.0 m·kg, 22 ft·lb)  
LOCTITE®

## 4. Install:

- Slide bush ①

Into outer tube.

Use the Fork Seal Driver Weight ③ (YM-33963) and the Adapter ② (YM-08010).

- ④ Inner tube
- ⑤ Outer tube

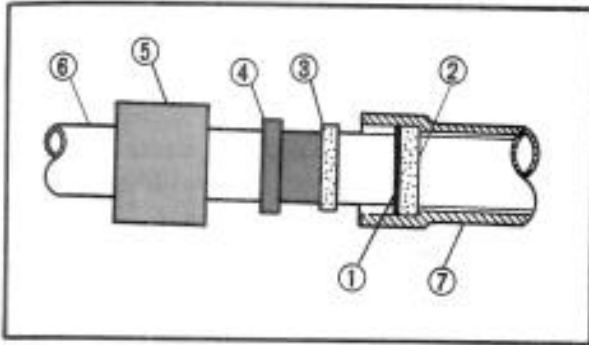

## 5. Install:

- Seal spacer ①  
On top of the slide bush ②.
- Oil seal ③  
Use the Fork Seal Driver Weight ⑤ (YM-33963) and the Adapter ④ (YM-08010), and install with numbered side up.

- ⑥ Inner tube
- ⑦ Outer tube

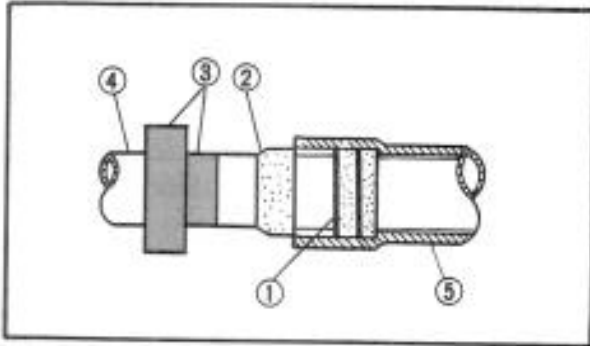

## 6. Install:

- Retaining clip ①
- Dust seal ②  
Use the Special Tools ③ (YM-33963, YM-08010)

- ④ Inner tube
- ⑤ Outer tube

## 7. Fill:

- Front fork



Each Fork:  
310 cm<sup>3</sup> (10.9 Imp oz, 10.5 US oz)  
Yamaha fork oil 10wt or equivalent  
After filling, slowly pump the fork up  
and down to distribute oil.

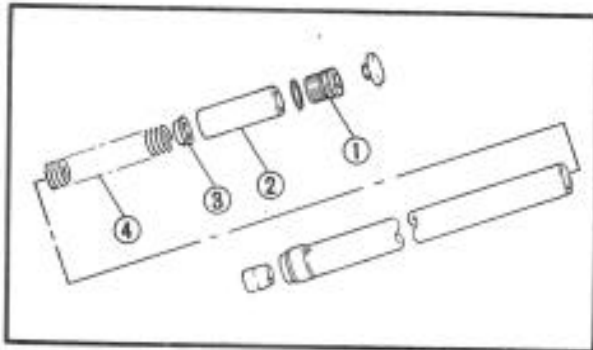

## 8. Install:

- Fork spring ④  
With smaller pitch side up.
- Spring seat ③
- Collar ②
- Cap bolt ①  
Temporarily tighten the cap bolt.

## INSTALLATION

## 1. Install:

- Front fork(s)  
Into underbracket.

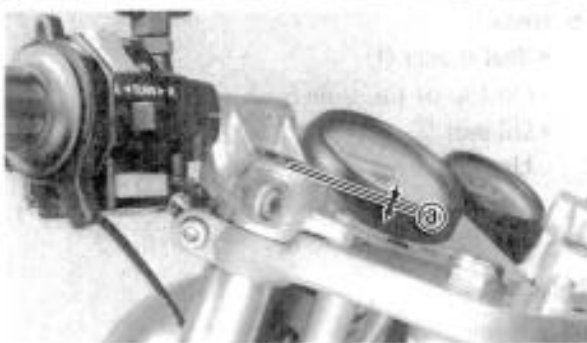

2. Tighten:
- Pinch bolts (Under bracket)
- Temporarily tighten the pinch bolts.

**NOTE:** \_\_\_\_\_  
 Position the inner tube end so that it is flush (a) with the top of the steering crown.

3. Tighten:
- Pinch bolts (Under bracket)

	<p><b>Pinch Bolts (Under Bracket):</b>                  38 Nm (3.8 m·kg, 27 ft·lb)</p>
---	--

**NOTE:** \_\_\_\_\_  
 Do not tighten the pinch bolt (Steering crown) in this stage.



4. Tighten:
- Cap bolt  
 Use the Front Fork Cap Socket (YM-01104).
  - Pinch bolts (Steering crown) ①
  - Pinch bolts (Handlebar) ②

	<p><b>Cap Bolt:</b>                  23 Nm (2.3 m·kg, 17 ft·lb)</p> <p><b>Pinch Bolts (Steering Crown):</b>                  20 Nm (2.0 m·kg, 14 ft·lb)</p> <p><b>Pinch Bolts (Handlebar):</b>                  20 Nm (2.0 m·kg, 14 ft·lb)</p>
---	--

5. Install:
- Fork cap
  - Brake calipers  
 Refer to "FRONT AND REAR BRAKE" section.
  - Front wheel  
 Refer to "FRONT WHEEL" section.

## STEERING HEAD

- |                              |                              |
|------------------------------|------------------------------|
| ① Steering stem nut          | ⑧ Ball race (Under – Top)    |
| ② Steering crown             | ⑨ Ball (19 pcs.)             |
| ③ Ring nut                   | ⑩ Ball race (Under – Bottom) |
| ④ Bearing cover              | ⑪ Steering seal              |
| ⑤ Ball race (Upper – Top)    | ⑫ Steering stem              |
| ⑥ Ball (19 pcs.)             |                              |
| ⑦ Ball race (Upper – Bottom) |                              |

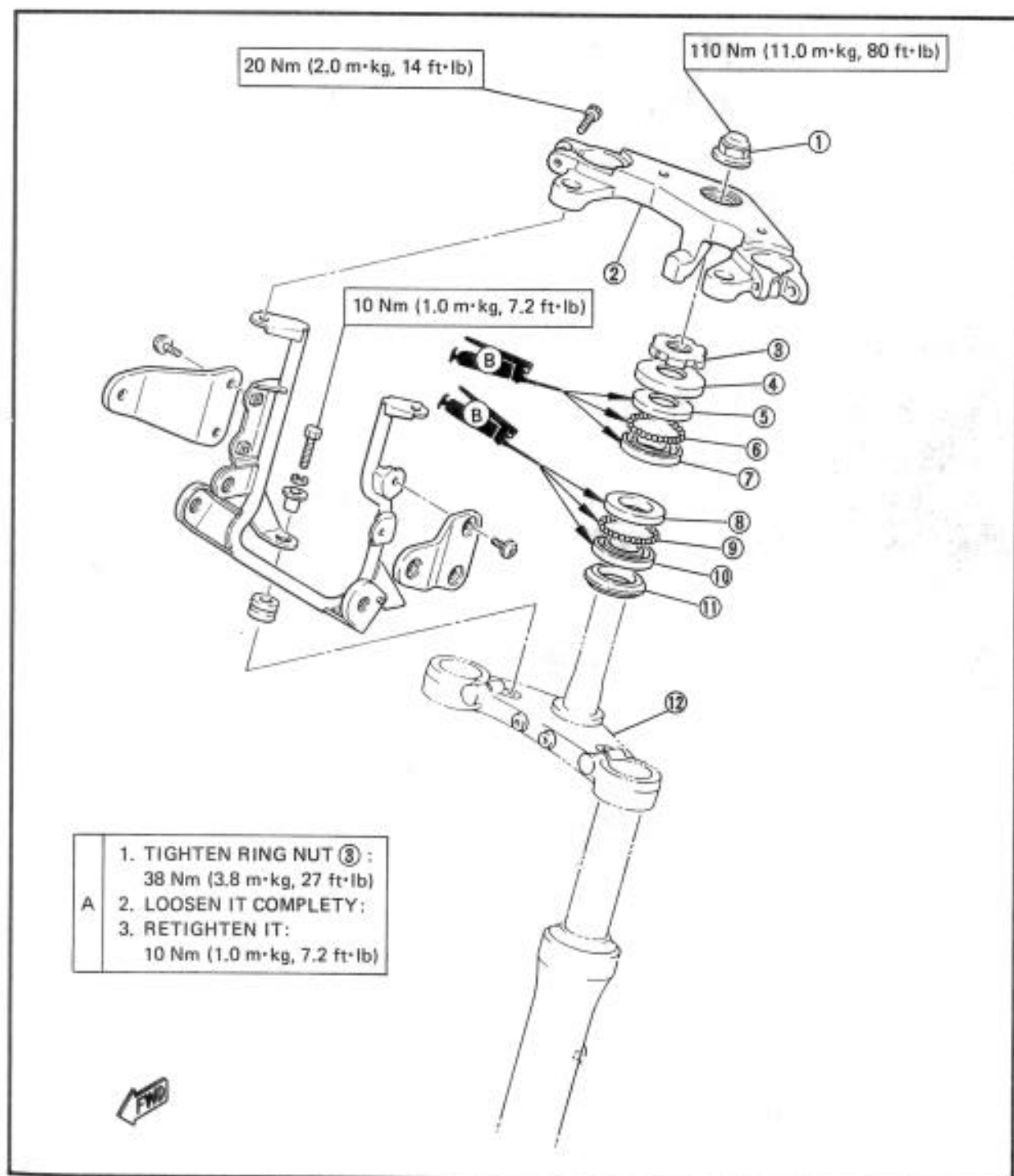

## REMOVAL

**WARNING:**

Securely support the motorcycle so there is no danger of it falling over.

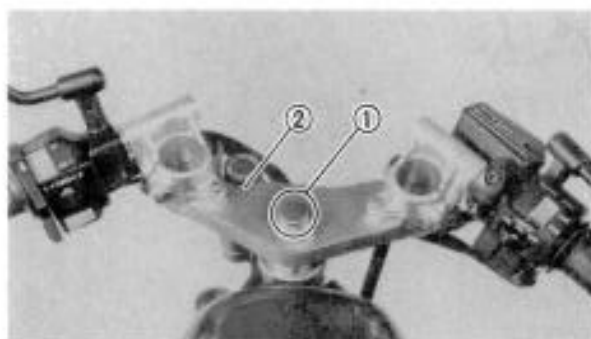
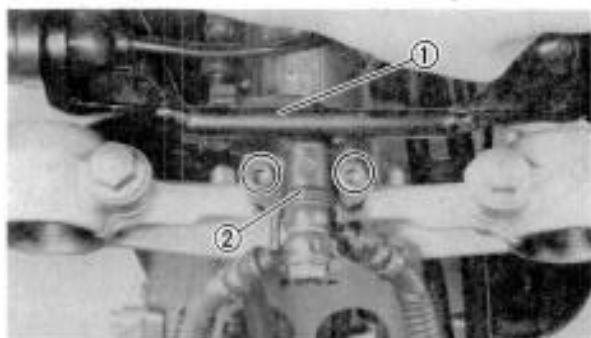

1. Remove:
  - Front wheel
  - Front forks
2. Remove:
  - Headlight lens unit ①
3. Disconnect:
  - All leads (In the headlight body)
4. Remove:
  - Headlight body ①
  - Nuts (Headlight stay) ②
  - Bolts (Headlight stay) ③
5. Disconnect:
  - Tachometer cable
  - Speedometer cable
6. Remove:
  - Meter assembly
  - Headlight stay ①
  - Brake hose joint ②
7. Remove:
  - Nut (Steering crown) ①
  - Steering crown ②

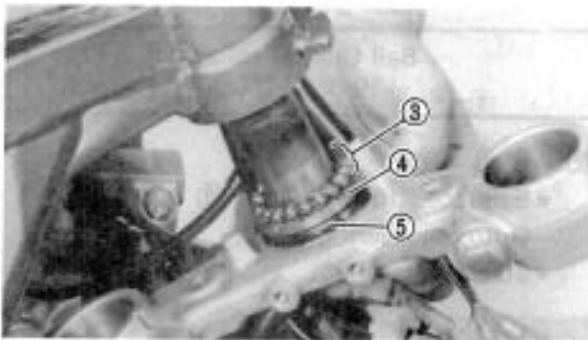
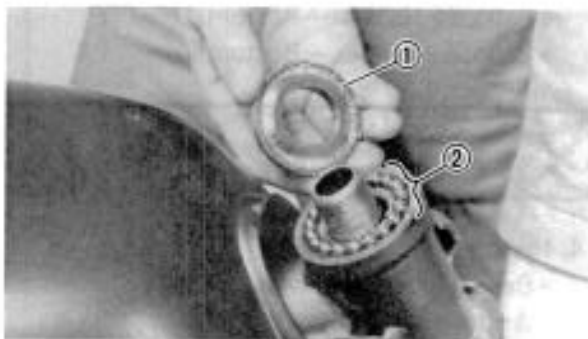
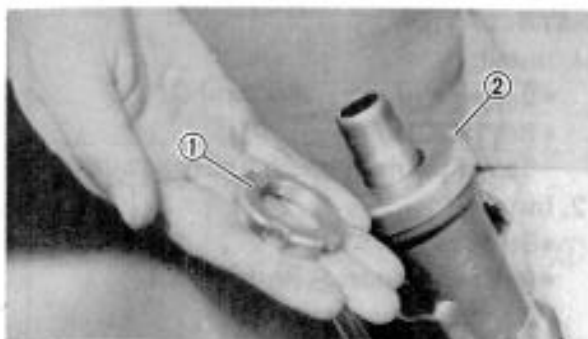

## 8. Remove:

- Ring nut ①
- Use the Ring Nut Wrench (YU-01268).
- Bearing cover ②

**WARNING:**

Support the under bracket so that it may not fall down.

## 9. Remove:

- Steering stem ①
- Ball race (Upper – Top) ①
- Ball (19 pcs.) ②
- Ball (19 pcs.) ③
- Ball race (Under – Bottom) ④
- Steering seal ⑤

## 10. Remove:

- Ball race (Upper – Bottom)
- Ball race (Under – Top)
- Use a drift punch and a hammer.

**NOTE:**

Work the race out gradually by tapping lightly around its complete backside diameter.

**INSPECTION**

1. Wash the bearing in a solvent.
2. Inspect:
  - Balls
  - Ball races
  - Pitting/Damage → Replace.

**NOTE:**

Always replace ball and race as a set.

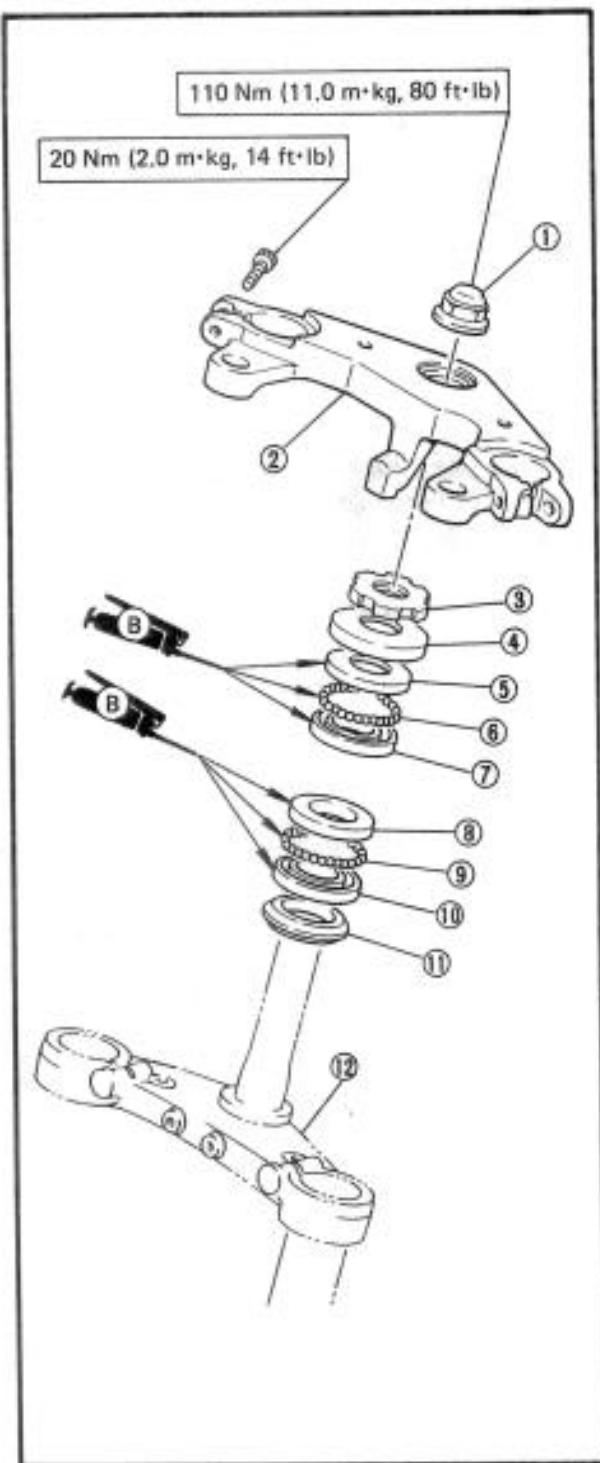

**INSTALLATION**

1. Install:
  - Ball race (Upper – Bottom) ⑦
  - Ball race (Under – Top) ⑧
  - Tap in the new races in the head pipe.
2. Install:
  - Steering seal ⑪
  - Ball race (Under – Bottom) ⑩
  - To the steering stem.
3. Lubricate:
  - Ball race (Upper – Bottom)
  - Ball race (Under – Bottom)

 **Wheel Bearing Grease**

4. Install:
  - Balls (Upper and lower) ⑥ ⑨
  - Arrange the balls around race, and apply more grease.

**Ball Quantity/Size:**  
19 pcs./ 1/4 in

5. Install:
  - Ball race (Under – Top) ⑧
  - Onto the steering stem.
  - Steering stem ⑫

**CAUTION:** \_\_\_\_\_  
**Hold the steering stem until it is secured.**

- Ball race (Upper – Top) ⑤
- Bearing cover ④
- Ring nut ③

**NOTE:** \_\_\_\_\_  
The tapered side of ring nut must face downward.

6. Tighten:
  - Ring nut ③

**Ring nut tightening steps:**  
**NOTE:** \_\_\_\_\_  
Set the Torque Wrench to the Ring Nut Wrench so that they form a right angle.



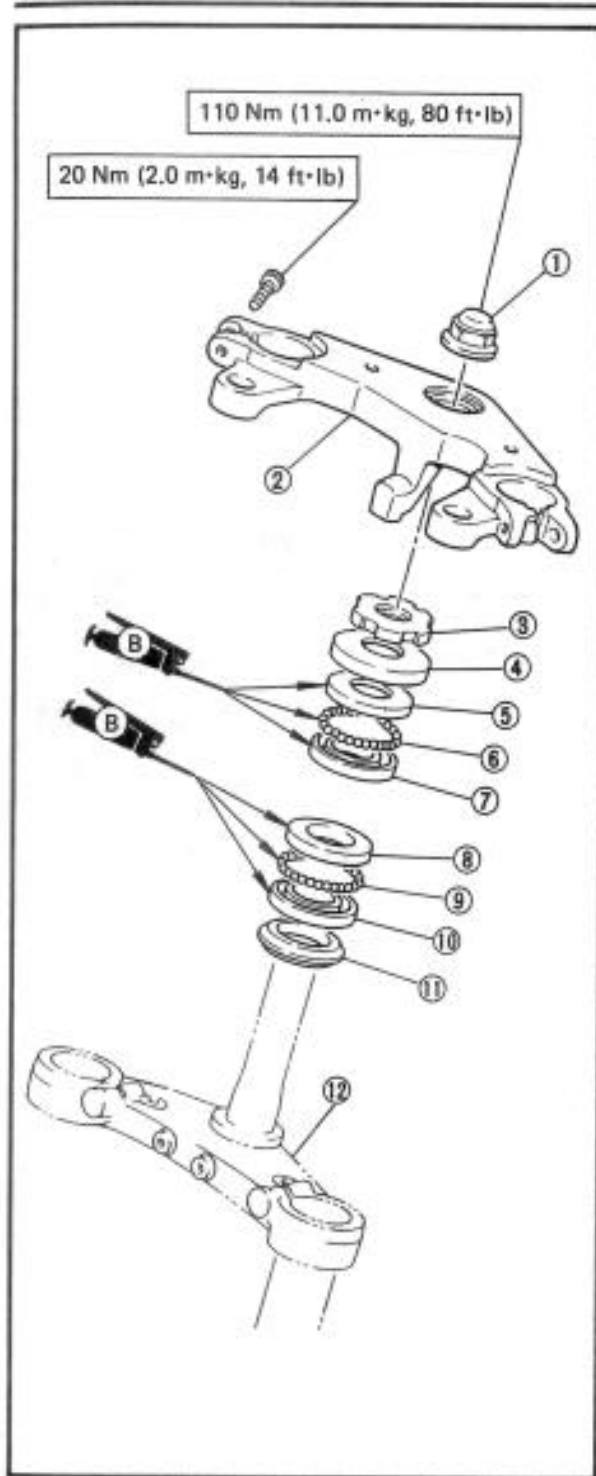

- Tighten the ring nut ③ using the Ring Nut Wrench (YU-01268).



**Ring Nut (Initial Tightening):**  
38 Nm (3.8 m·kg, 27 ft·lb)

- Loosen the ring nut ③ completely and retighten it to specification.

**WARNING:**

Do not over-tightening.



**Ring Nut (Final Tightening):**  
10 Nm (1.0 m·kg, 7.2 ft·lb)

- Check the steering stem by turning it lock to lock. If there is any binding, remove the steering stem assembly and inspect the steering bearings ⑥, ⑩.
- Install the steering crown ② and tighten the steering stem nut ① to specification.



**Nut (Steering stem):**  
110 Nm (11.0 m·kg, 80 ft·lb)

7. Install:

- Components in aforementioned list (Steps "5 ~ 1")  
Refer to "FRONT FORK" and "FRONT WHEEL" section.



**Headlight Stay:**  
10 Nm (1.0 m·kg, 7.2 ft·lb)  
**Pinch Bolts (Steering Crown):**  
20 Nm (2.0 m·kg, 14 ft·lb)  
**Pinch Bolts (Handlebar):**  
20 Nm (2.0 m·kg, 14 ft·lb)

8. Adjust:

- Headlight beam  
Refer to "CHAPTER 2. HEADLIGHT BEAM ADJUSTMENT" section.

**REAR SHOCK ABSORBER**

① Rear shock absorber assembly

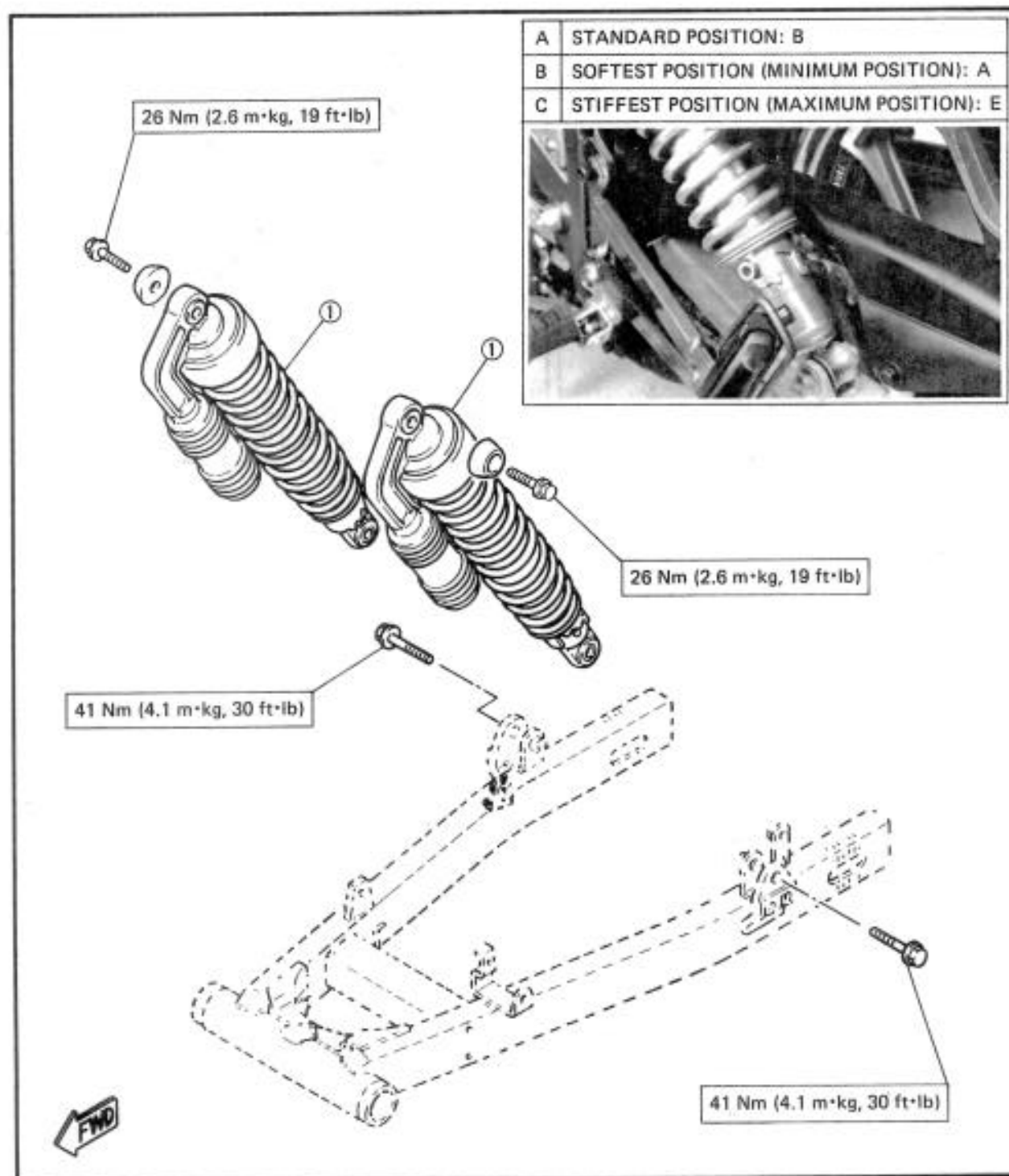

## HANDLING NOTES

**WARNING:**

This shock absorber contains highly pressurized nitrogen gas. Read and understand the following information before handling the shock absorber. The manufacturer cannot be held responsible for property damage or personal injury that may result from improper handling.

- Do not tamper with or attempt to open the cylinder assembly.
- Do not subject shock absorber to an open flame or other high heat source. This may cause the unit to explode due to excessive gas pressure.
- Do not deform or damage the cylinder in any way. Cylinder damage will result in poor damping performance.
- Take care not to scratch the contact surface of the piston rod with the cylinder; or oil could leak out.
- When scrapping the shock absorber, follow the instructions on disposal.

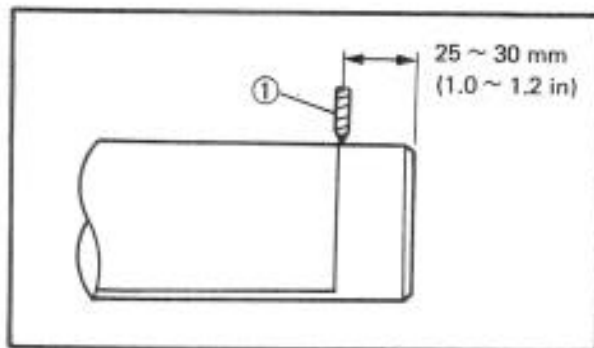

## NOTES ON DISPOSAL

**Shock absorber disposal steps:**

Gas pressure must be released before disposing of shock absorber. To do so, drill ① a 2 ~ 3 mm (0.08 ~ 0.12 in) hole through the cylinder wall at a point 25 ~ 30 mm (1.0 ~ 1.2 in) from the bottom end of the gas chamber.

**CAUTION:**

Wear eye protection to prevent eye damage from escaping gas and/or metal chips.

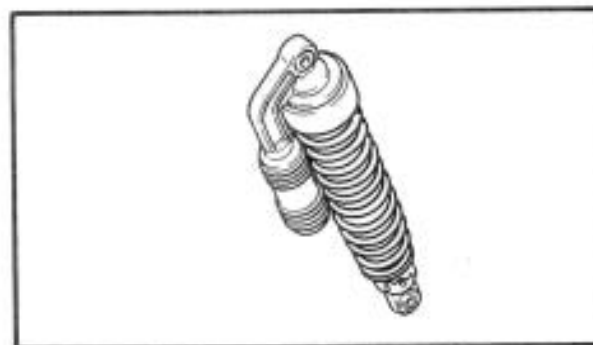
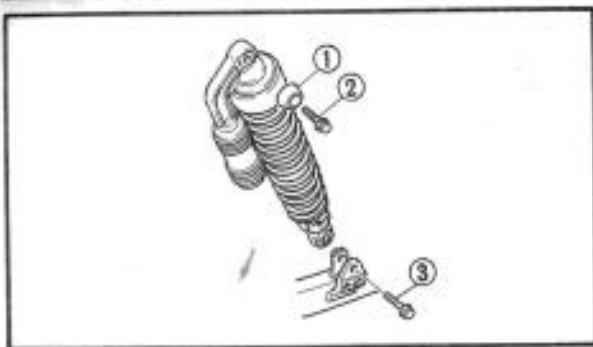

## REMOVAL

1. Remove:
  - Bolt (Shock absorber top) ①
  - Special washer ②
  - Bolt (Shock absorber bottom) ③
2. Pull out the shock absorber top, and turn the shock absorber clockwise.
3. Remove:
  - Rear shock absorber

## INSPECTION

1. Inspect:
  - Shock absorber rod  
Bends/Damage → Replace the shock absorber assembly.
  - Shock absorber  
Oil leaks → Replace the shock absorber assembly.
  - Spring  
Fatigue → Replace the shock absorber assembly.  
Move the spring up and down.

## INSTALLATION

When installing the rear shock absorber, reverse the removal procedure. Note the following points.

1. Apply:
  - Lithium base grease  
To the pivot points.

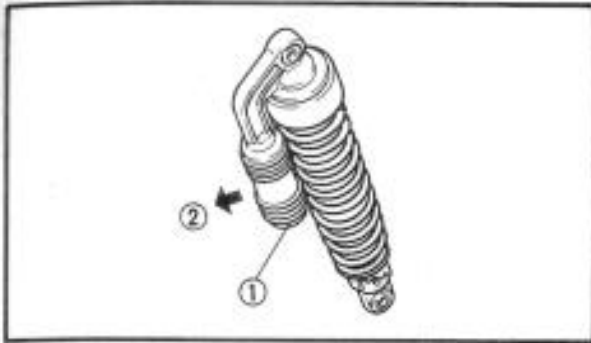

2. Install:
- Rear shock absorber

**NOTE:** \_\_\_\_\_  
The rear shock absorber should be installed so that the gas chamber ① on the shock absorber faces forward ② .

3. Tighten:
- Bolt (Shock absorber top)
  - Nut (Shock absorber bottom)



**Bolt (Shock Absorber Top):**  
26 Nm (2.6 m·kg, 19 ft·lb)

**Bolt (Shock Absorber Bottom):**  
41 Nm (4.1 m·kg, 30 ft·lb)

4. Adjust:
- Spring preload
- Refer to "CHAPTER 2. REAR SHOCK ABSORBER ADJUSTMENT" section.

**SWINGARM**

- ① Pivot shaft
- ② Thrust cover
- ③ Plain washer
- ④ Taper roller bearing
- ⑤ Chain guide
- ⑥ Bushing

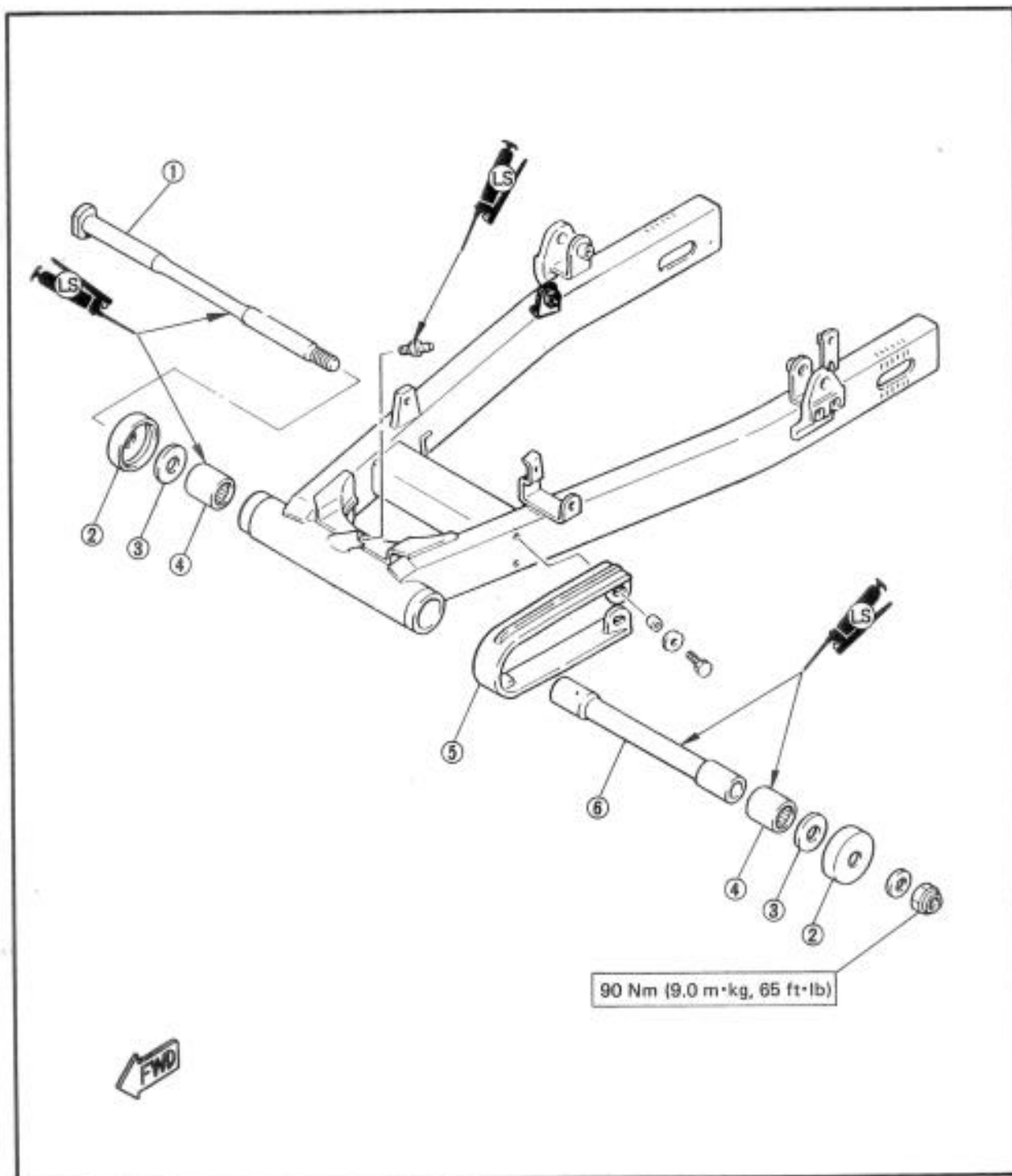

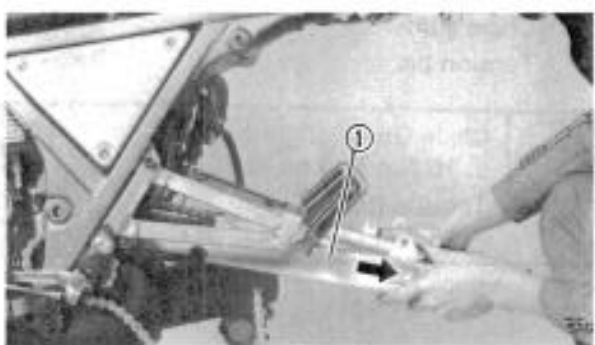
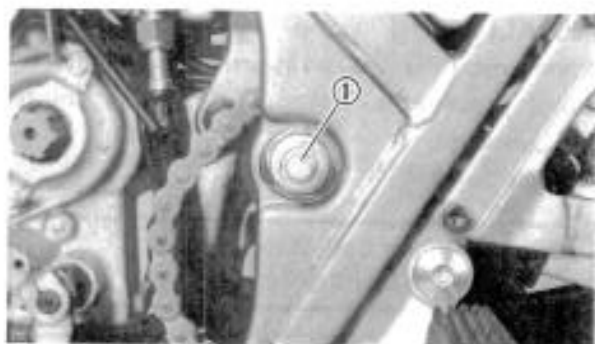
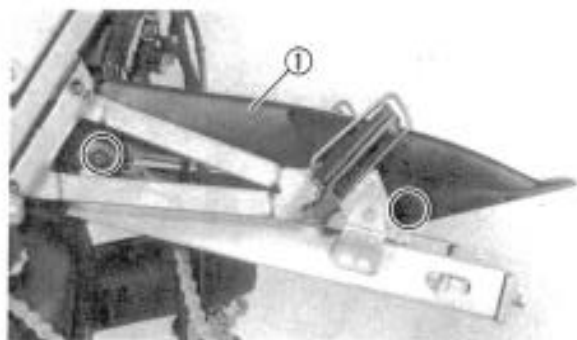
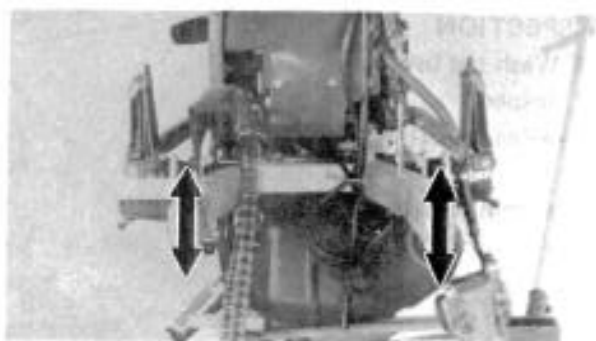
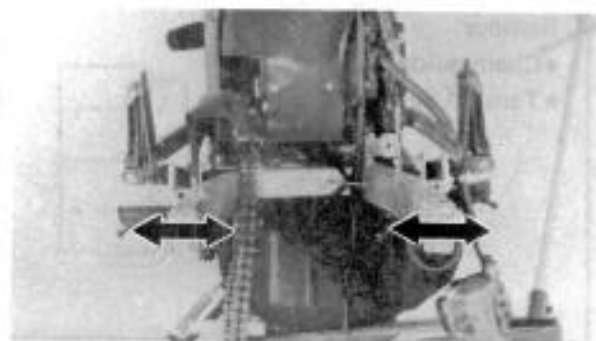
**FREE PLAY INSPECTION**

1. Remove:
  - Rear wheel
  - Rear shock absorbers
2. Check:
  - Swingarm (Side play)
    - Side play → Replace taper roller bearings and bushing.
    - Move the swingarm from side to side.



**Side Play (At End of Swingarm):**  
1.0 mm (0.04 in)

3. Check:
  - Swingarm (Vertical movement)
    - Tightness/Binding/Rough spots → Replace bearings.
    - Move the swingarm up and down.

**REMOVAL**

1. Remove:
  - Rear wheel
  - Rear shock absorbers
  - Chain case ①

**NOTE:** \_\_\_\_\_  
Before removing the rear wheel, remove the drive sprocket and drive chain.  
\_\_\_\_\_

2. Remove:
  - Pivot shaft ①
    - Pull out the pivot shaft.

3. Remove:
  - Swingarm ①

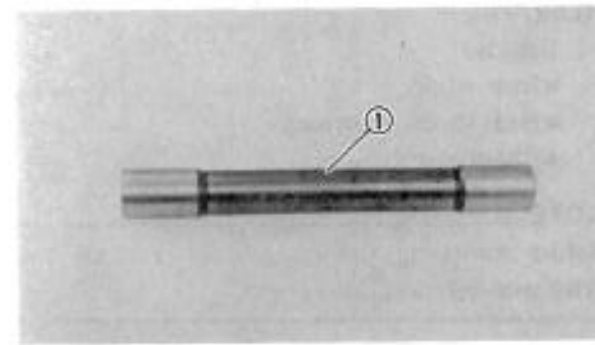
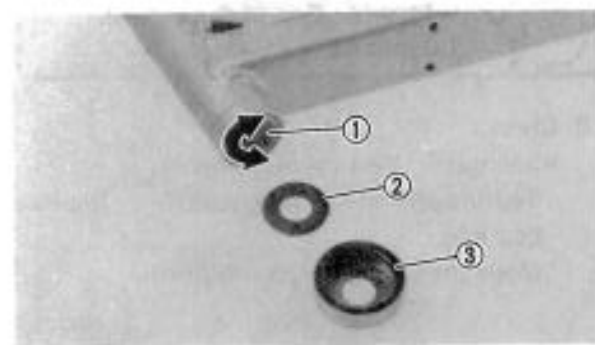
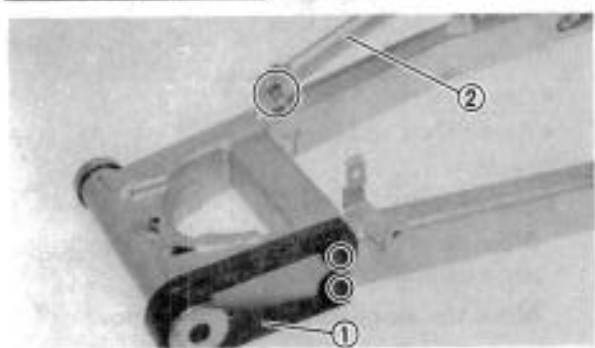

4. Remove:
- Chain guide ①
  - Tension bar ②

**INSPECTION**

1. Wash the bearings in a solvent.
2. Inspect:
  - Bearings (Race/Rollers) ①  
Pitting/Damage → Replace.
  - Plain washer ②
  - Thrust cover ③  
Damage → Replace.
3. Inspect:
  - Bushing ①  
Scratches/Damage → Replace.

**INSTALLATION**

When installing the swingarm, reverse the removal procedures. Note the following points.

1. Lubricate:
  - Bearings

	<b>Lithium Base Waterproof Wheel Bearing Grease</b>
---	---

2. Install:
  - Chain guide
  - Tension bar

	<b>Chain Guide:</b> 10 Nm (1.0 m·kg, 7.2 ft·lb)
	<b>Tension Bar:</b> 25 Nm (2.5 m·kg, 18 ft·lb)

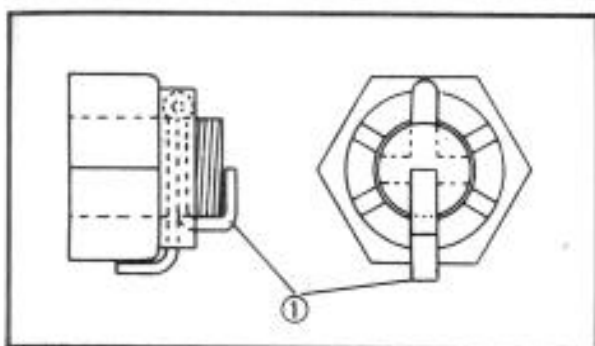

**NOTE:**

Always use new cotter pins ① on the tension bar bolts.

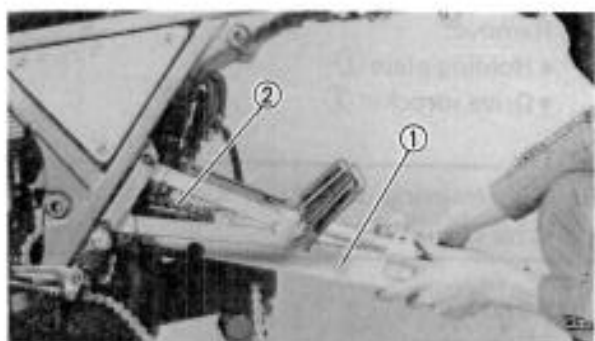
**3. Install:**

- Swingarm ①
- Pivot shaft

**NOTE:**

Before installing the swingarm ①, fit the drive chain ② to the swingarm.

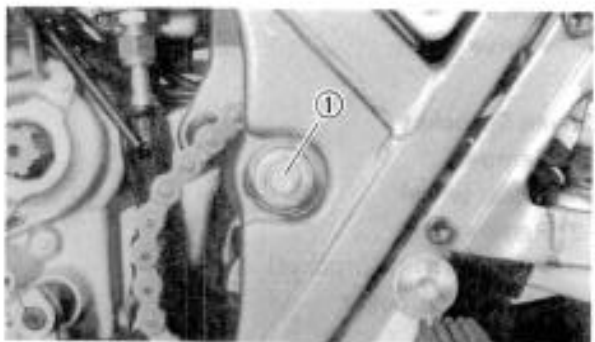
**4. Tighten:**

- Nut (Pivot shaft) ①



**Nut (Pivot Shaft):**  
90 Nm (9.0 m·kg, 65 ft·lb)

**5. Check:**

- Swingarm (Side play)
  - Swingarm (Vertical movement)
- Refer to "FREE PLAY INSPECTION" section.

**6. Lubricate:**

- Grease nipple ①
- Using a grease gun.

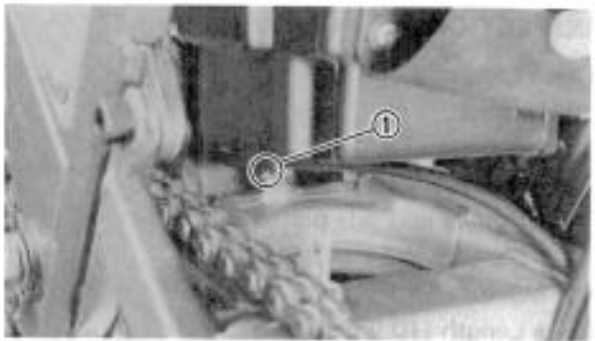

**Lithium Base Waterproof  
Wheel Bearing Grease**

**7. Install:**

- Chain case ①
  - Rear shock absorbers
  - Rear wheel
- Refer to "REAR SHOCK ABSORBER" and "REAR WHEEL" section.
- Drive sprocket

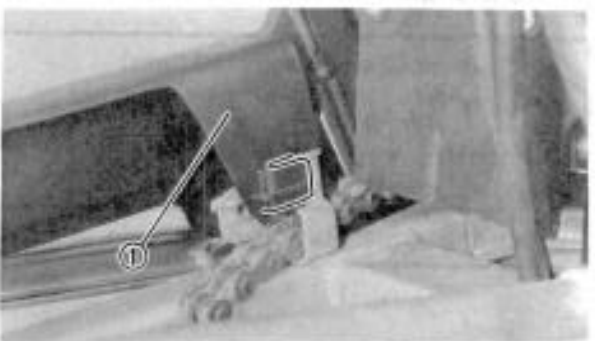

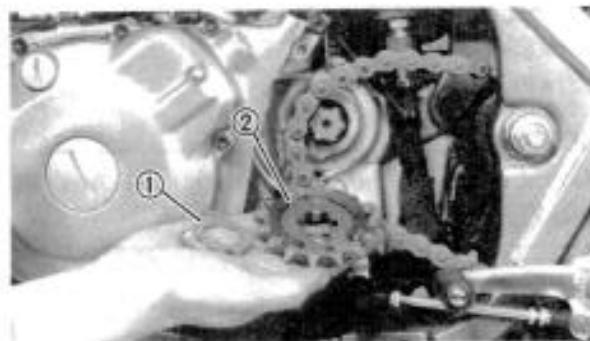
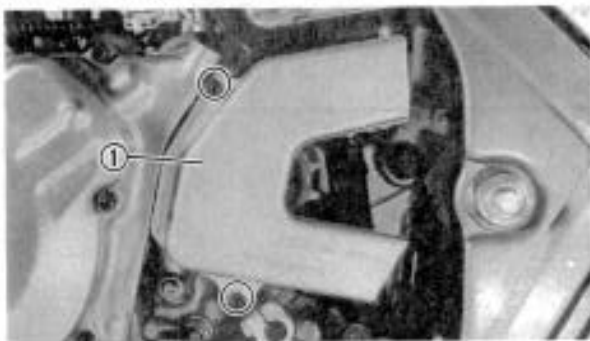

## DRIVE CHAIN AND SPROCKETS

### REMOVAL

#### Drive Sprocket and Drive Chain

1. Remove:
  - Sprocket cover ①
  - Bolts (Drive sprocket)Apply the rear brake.

2. Remove:
  - Holding plate ①
  - Drive sprocket ②

#### NOTE:

Before removing the drive sprocket, increase the drive chain slack.

3. Remove:
  - Rear wheel
  - Swingarm
  - Drive chain

#### Driven Sprocket

1. Remove:
  - Rear wheel
2. Remove:
  - Bolts (Drive sprocket)
  - Driven sprocket

### INSPECTION

#### Drive Chain

1. Inspect:
  - O-rings  
Damage/Miss → Replace.
  - Rollers and side plates  
Damage/Wear → Replace.
2. Measure:
  - Length (10 links) ①Out of specification → Replace.

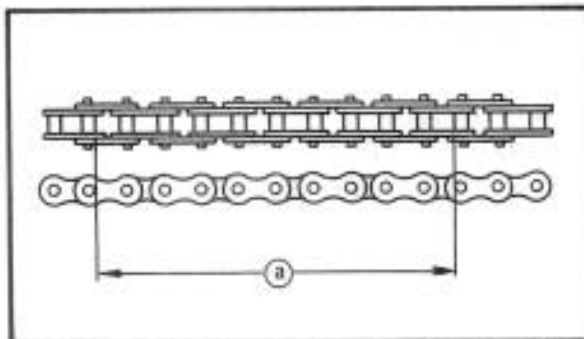

Drive Chain Length (10 links)  
Limit:  
150.08 mm (5.91 in)

#### NOTE:

Replace the sprockets and drive chain as a set.

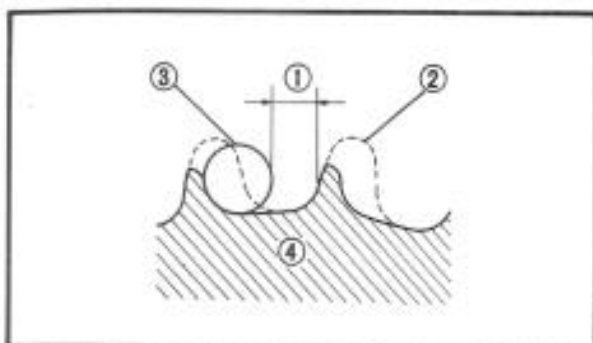
**Drive and Driven Sprockets****1. Inspect:**

- Drive and driven sprockets  
Wear/Damage → Replace.

- ① 1/4 tooth
- ② Correct
- ③ Roller
- ④ Sprocket

**ASSEMBLY**

When assembling the sprockets, reverse the removal procedure. Note the following points.

**1. Tighten:**

- Bolts (Drive sprocket)
- Bolts (Driven sprocket)



**Bolts (Drive Sprocket):**  
20 Nm (2.0 m·kg, 14 ft·lb)  
LOCTITE®

**Bolts (Drive Sprcoket):**  
32 Nm (3.2 m·kg, 23 ft·lb)  
LOCTITE®

**2. Adjust:**

- Drive chain slack
- Rear brake free play  
Refer to "CHAPTER 2. DRIVE CHAIN SLACK ADJUSTMENT and REAR BRAKE ADJUSTMENT" section.