

**CHAPTER 6.  
ELECTRICAL**

**SRX600S/SC CIRCUIT DIAGRAM** ..... 6-1

**ELECTRICAL COMPONENTS**..... 6-3

**IGNITION SYSTEM** ..... 6-5

**CIRCUIT DIAGRAM** ..... 6-5

**TROUBLESHOOTING** ..... 6-7

**IGNITION CONTROL CIRCUIT OPERATION** ..... 6-12

**CHARGING SYSTEM**..... 6-13

**CIRCUIT DIAGRAM** ..... 6-13

**TROUBLESHOOTING** ..... 6-15

**LIGHTING SYSTEM** ..... 6-17

**CIRCUIT DIAGRAM** ..... 6-17

**TROUBLESHOOTING** ..... 6-19

**SIGNAL SYSTEM** ..... 6-23

**CIRCUIT DIAGRAM** ..... 6-23

**TROUBLESHOOTING** ..... 6-25

**SELF-CANCELLING FALSHER SYSTEM**..... 6-31

**SWITCHES TEST** ..... 6-31



ELECTRICAL

SRX600S/SC CIRCUIT DIAGRAM

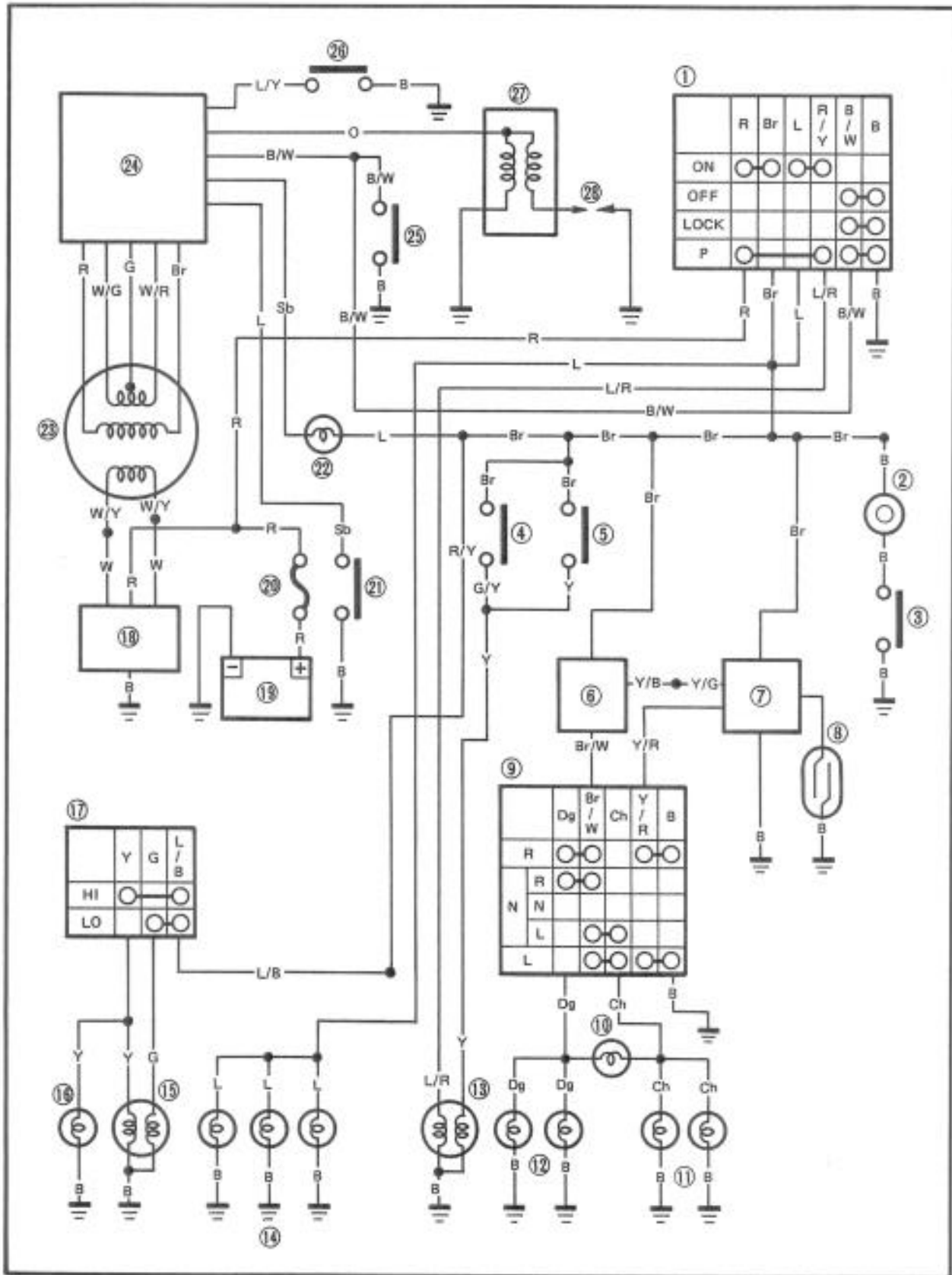



- ① Main switch
- ② Horn
- ③ "HORN" switch
- ④ Front brake switch
- ⑤ Rear brake switch
- ⑥ Flasher relay
- ⑦ Cancelling unit
- ⑧ Reed switch
- ⑨ "TURN" switch
- ⑩ "TURN" indicator light
- ⑪ Flasher light (Left)
- ⑫ Flasher light (Right)
- ⑬ Tail/brake light
- ⑭ Meter light
- ⑮ Headlight
- ⑯ "HIGH BEAM" indicator light
- ⑰ "LIGHTS" (Dimmer) switch
- ⑱ Rectifier/regulator
- ⑲ Battery
- ⑳ Circuit breaker
- ㉑ Neutral switch
- ㉒ "NEUTRAL" indicator light
- ㉓ CDI magneto
- ㉔ CDI unit
- ㉕ "ENGINE STOP" switch
- ㉖ Sidestand switch
- ㉗ Ignition coil
- ㉘ Spark plug

## COLOR CODE

B . . . . .	.Black
R . . . . .	.Red
L . . . . .	.Blue
G . . . . .	.Green
Dg . . . . .	.Dark green
Sb . . . . .	.Sky blue
Br. . . . .	.Brown
O . . . . .	.Orange
Y . . . . .	.Yellow
Ch . . . . .	.Chocolate
P . . . . .	.Pink
W . . . . .	.White
B/W . . . . .	.Black/White
R/Y . . . . .	.Red/Yellow
L/B. . . . .	.Blue/Black
L/R . . . . .	.Blue/Red
L/Y . . . . .	.Blue/Yellow
G/Y . . . . .	.Green/Yellow
Br/W . . . . .	.Brown/White
Y/B . . . . .	.Yellow/Black
Y/R . . . . .	.Yellow/Red
W/R . . . . .	.White/Red
W/G . . . . .	.White/Green
W/Y . . . . .	.White/Yellow



**ELECTRICAL COMPONENTS (1)**

- ① Wire harness
- ② Rectifier with regulator
- ③ CDI unit
- ④ Circuit breaker
- ⑤ Battery
- ⑥ Ignition coil
- ⑦ Main switch

SPECIFICATIONS	RESISTANCE
IGNITION COIL: PRIMARY	0.48 ~ 0.72Ω
SECONDARY	5.2 ~ 7.8 kΩ
PICKUP	92 ~ 138Ω

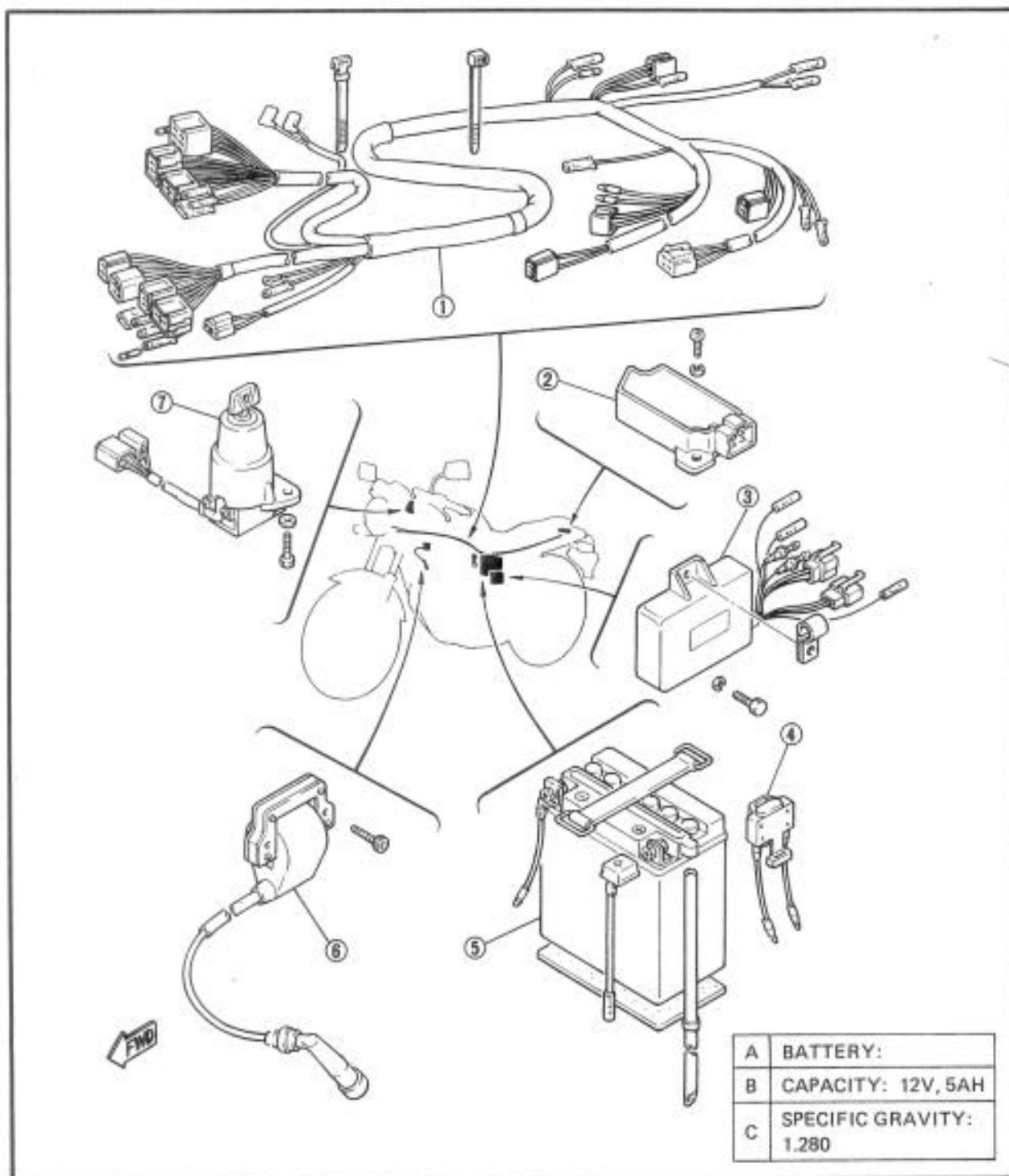



## ELECTRICAL COMPONENTS (2)

- ① Rear brake switch
- ② Sidestand switch
- ③ Neutral switch
- ④ Flasher relay
- ⑤ Horn

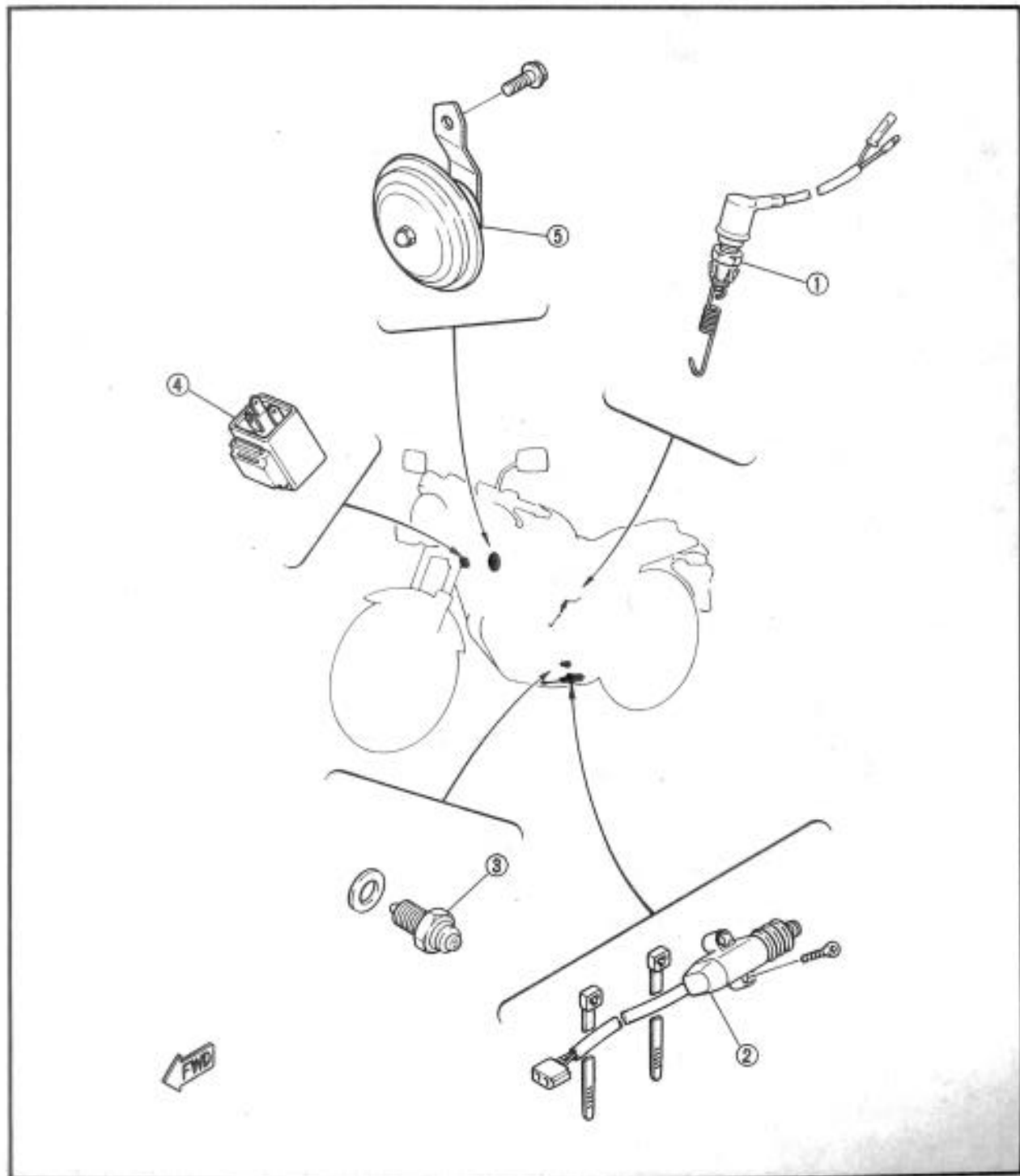



IGNITION SYSTEM

CIRCUIT DIAGRAM

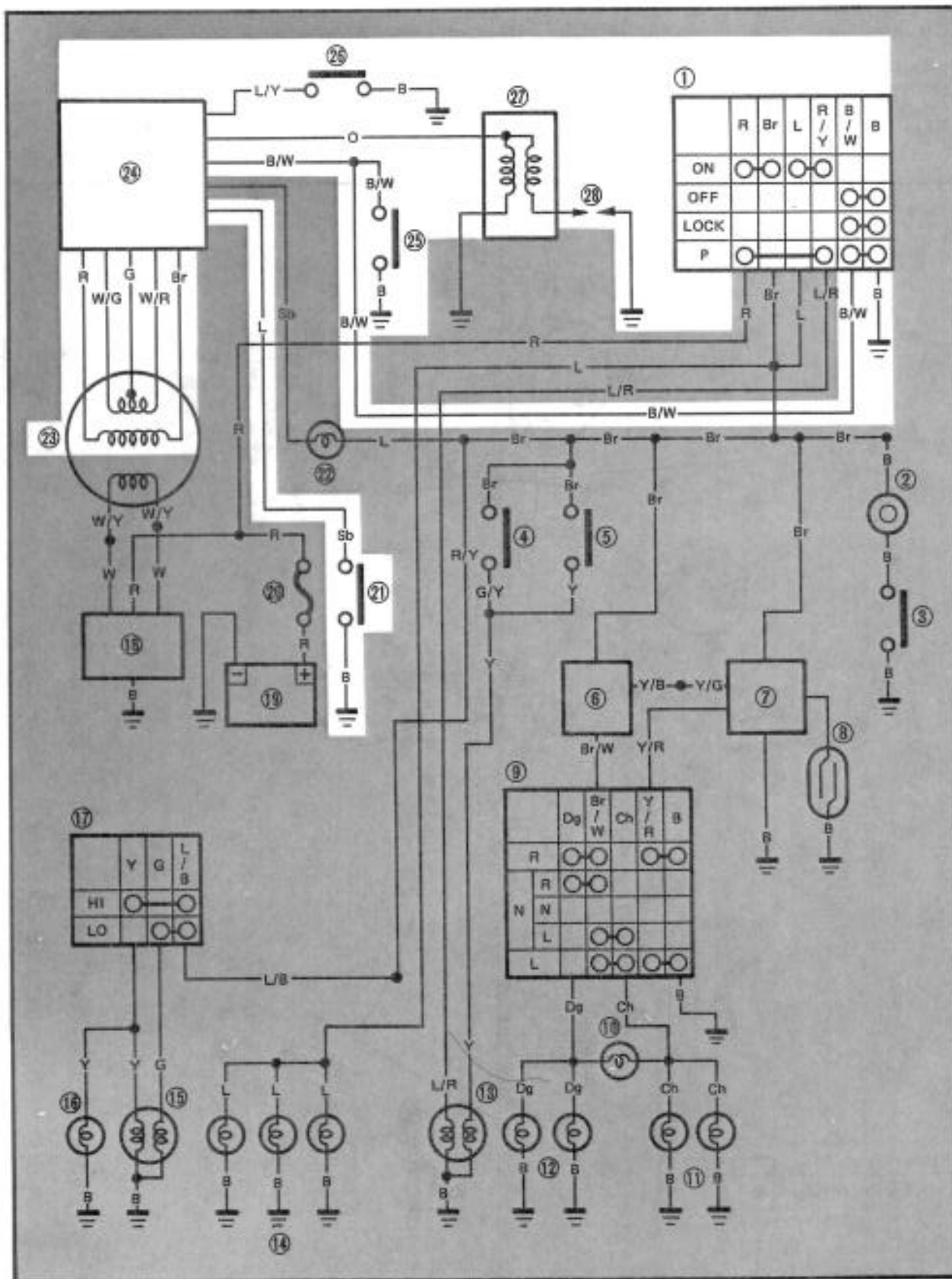



Aforementioned circuit diagram shows ignition circuit in wiring diagram.

**NOTE:**

For the encircled numbers and color codes, see page 6-2.

- ① Main switch
- ② Neutral switch
- ③ CDI magneto
- ④ CDI unit
- ⑤ "ENGINE STOP" switch
- ⑥ Sidestand switch
- ⑦ Ignition coil
- ⑧ Spark plug

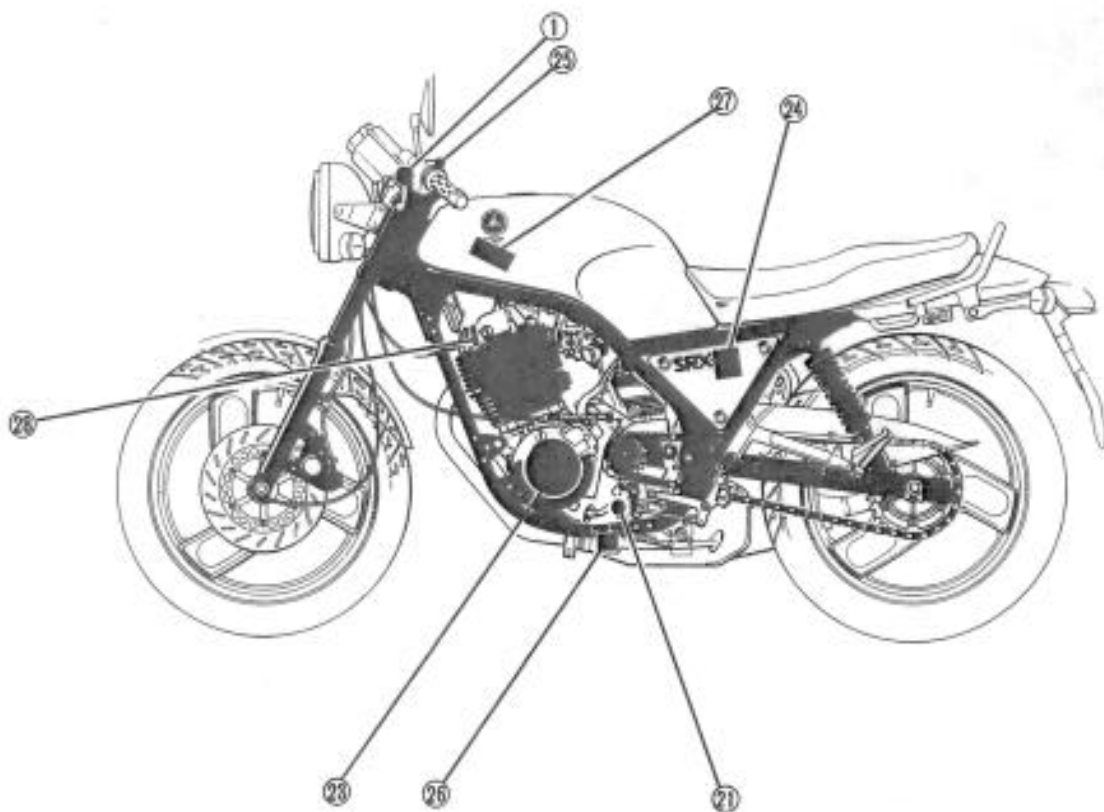



## TROUBLESHOOTING

## NOTE:

Before this troubleshooting, remove the side covers, seat and fuel tank.

IF IGNITION SYSTEM SHOULD BECOME INOPERATIVE (NO SPARK OR INTERMITTENT SPARK).

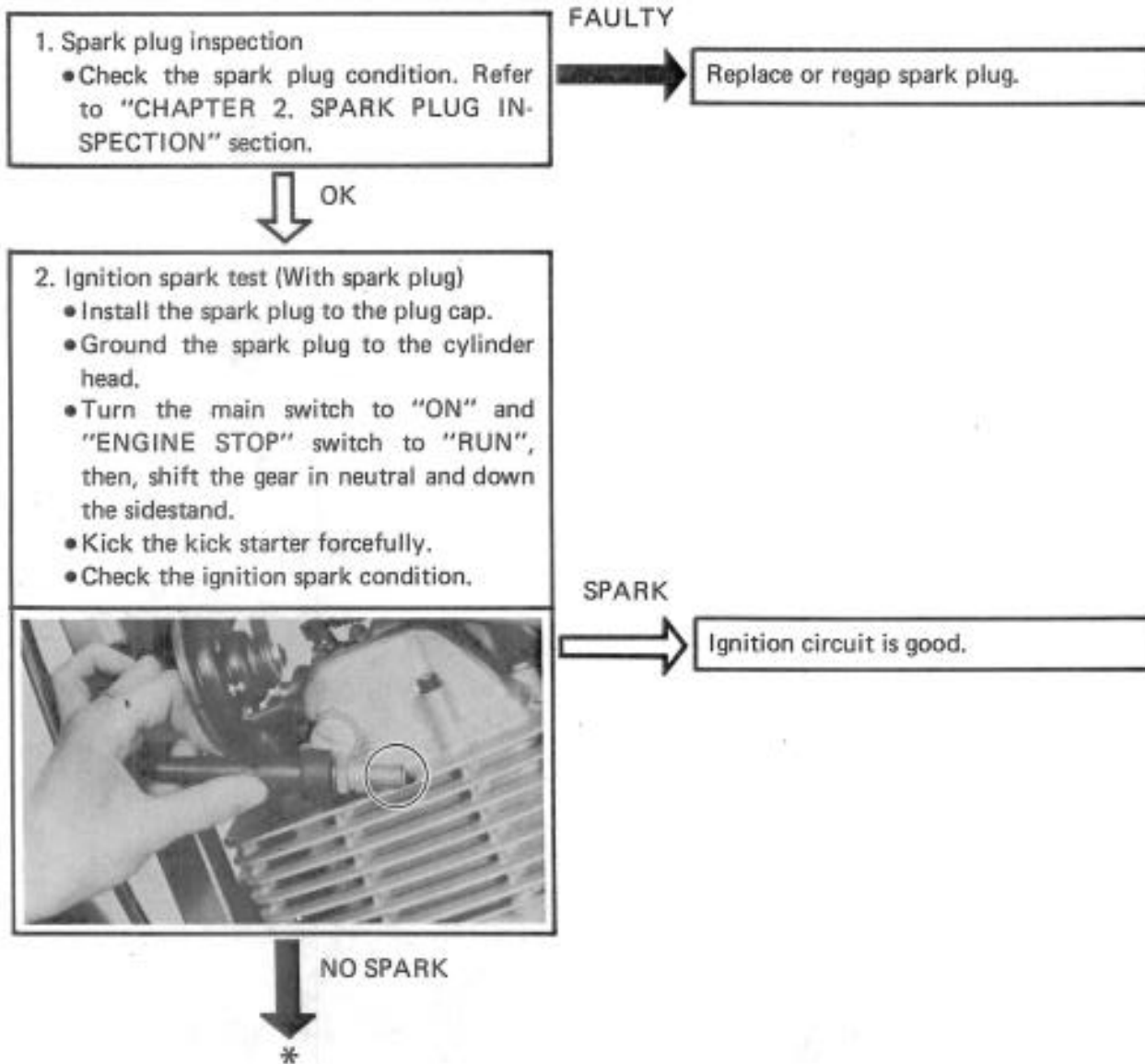





3. Ignition spark gap test (Without spark plug and cap)

- Remove the spark plug and plug cap.
- Hold the spark plug lead 6 mm (0.24 in) from the cylinder head.
- Repeat the aforementioned test.
- Check the ignition spark condition.

SPARK

Spark plug and/or plug cap is faulty. Replace faulty part(s).



NO SPARK

4. "ENGINE STOP" and main switches conduct check.

- Check the "ENGINE STOP" and main switches for continuity. Refer to "SIGNAL SYSTEM" section.

FAULTY

"ENGINE STOP" and/or main switches is faulty. Replace faulty part(s).

OK

5. Sidestand switch conduct check

- Disconnect the sidestand switch leads (Blue/Yellow ① and Black ② ) from the wire harness.
- Connect the Pocket Tester (YU-33260) to the sidestand switch leads.
- Move the sidestand up or down, and check the sidestand switch for continuity.

Sidestand Position	Good Condition	Bad Condition		
Up ③	○	○	X	X
Down ④	X	○	X	○

BAD CONDITION

Sidestand switch is faulty. Replace it.

○: Continuity X: Discontinuity

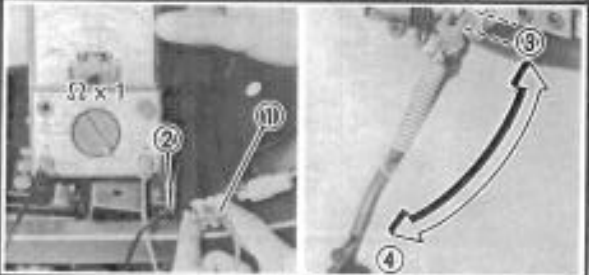

GOOD CONDITION





6. Neutral switch conduct check

- Disconnect the neutral switch lead (Sky blue ①) from the wire harness.
- Connect the positive lead of the Pocket Tester (YU-33260) to the neutral switch lead.
- Ground the negative lead of the Pocket Tester to the engine.
- Shift the gear, and check the neutral switch for continuity.

Transmission Position	Good Condition	Bad Condition		
In neutral	○	○	X	X
In gear	X	○	X	○

BAD CONDITION

Neutral switch is faulty.  
Replace it.

○: Continuity    X: Discontinuity



GOOD CONDITION

7. Ignition coil resistance test

- Disconnect the ignition coil lead (Orange ①) and spark plug lead ②.
- Connect the Pocket Tester (YU-33260) as shown.
- Measure the primary and secondary coil resistances.



Primary Coil Resistance [A] :  
0.48 ~ 0.72Ω at 20°C (68°F)  
Secondary Coil Resistance [B] :  
5.2 ~ 7.8 kΩ at 20°C (68°F)

OUT OF SPECIFICATION

Ignition coil is faulty.  
Replace it.

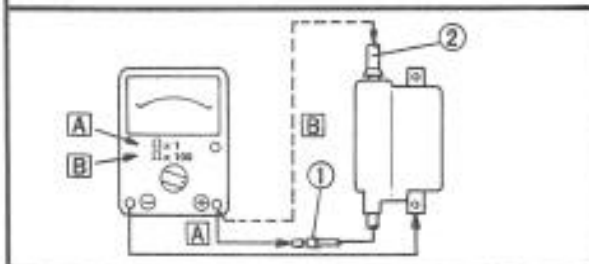

BOTH RESISTANCES  
\* MEET SPECIFICATIONS



8. Source coil resistance test

- Disconnect the CDI magneto leads Brown ① and Red ② ) from the wire harness.
- Connect the Pocket Tester (YU-33260) to the CDI magneto leads.
- Measure the source coil resistance.



**Source Coil Resistance**  
(Brown ① – Red ② ):  
84 ~ 156Ω at 20°C (68°F)

OUT OF SPECIFICATION

Source coil is faulty.  
Replace stator assembly.



9. Pickup coil resistance test

- Disconnect the pickup coil leads (White/Green ① , White/Red ② and Green ③ ) from the CDI unit.
- Connect the Pocket Tester (YU-33260) to the pickup coil leads.
- Measure the pickup coil resistance.



**Pickup Coil Resistance**  
(White/Green ① – Green ③ ,  
White/Red ② – Green ③ ):  
92 ~ 138Ω at 20°C (68°F)

OUT OF SPECIFICATION

Pickup coil is faulty.  
Replace stator assembly.

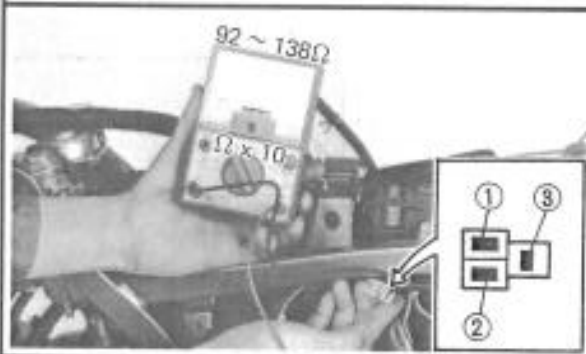

↓ BOTH RESISTANCES  
MEET SPECIFICATIONS  
\*

NOTE

page 3-54



10. Check entire ignition system for connections.  
• Refer to "WIRING DIAGRAM" section.

POOR CONNECTION



Correct.



OK

CDI unit is faulty. Replace it.

**IGNITION CONTROL CIRCUIT OPERATION**

The ignition control circuit on this model consists of the CDI unit, neutral switch and sidestand switch. If the engine stop switch and main switch are both on, the ignition spark can produce only if:

- The transmission is in neutral (The neutral switch is on).
- OR
- The sidestand is up (The sidestand switch is on).

When one of both of the above conditions have been met, and the engine can be started by kicking the kick starter.

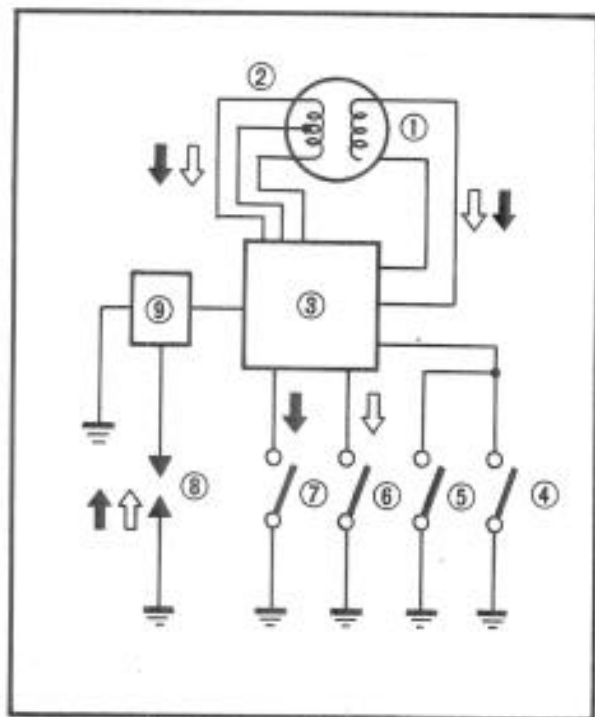
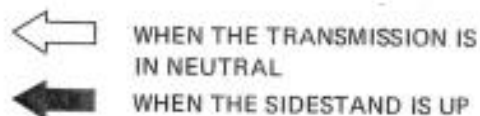

- ① Source coil
- ② Pickup coil
- ③ CDI unit
- ④ "ENGINE STOP" switch
- ⑤ Main switch
- ⑥ Neutral switch
- ⑦ Sidestand switch
- ⑧ Spark plug
- ⑨ Ignition coil



CHARGING SYSTEM

CIRCUIT DIAGRAM

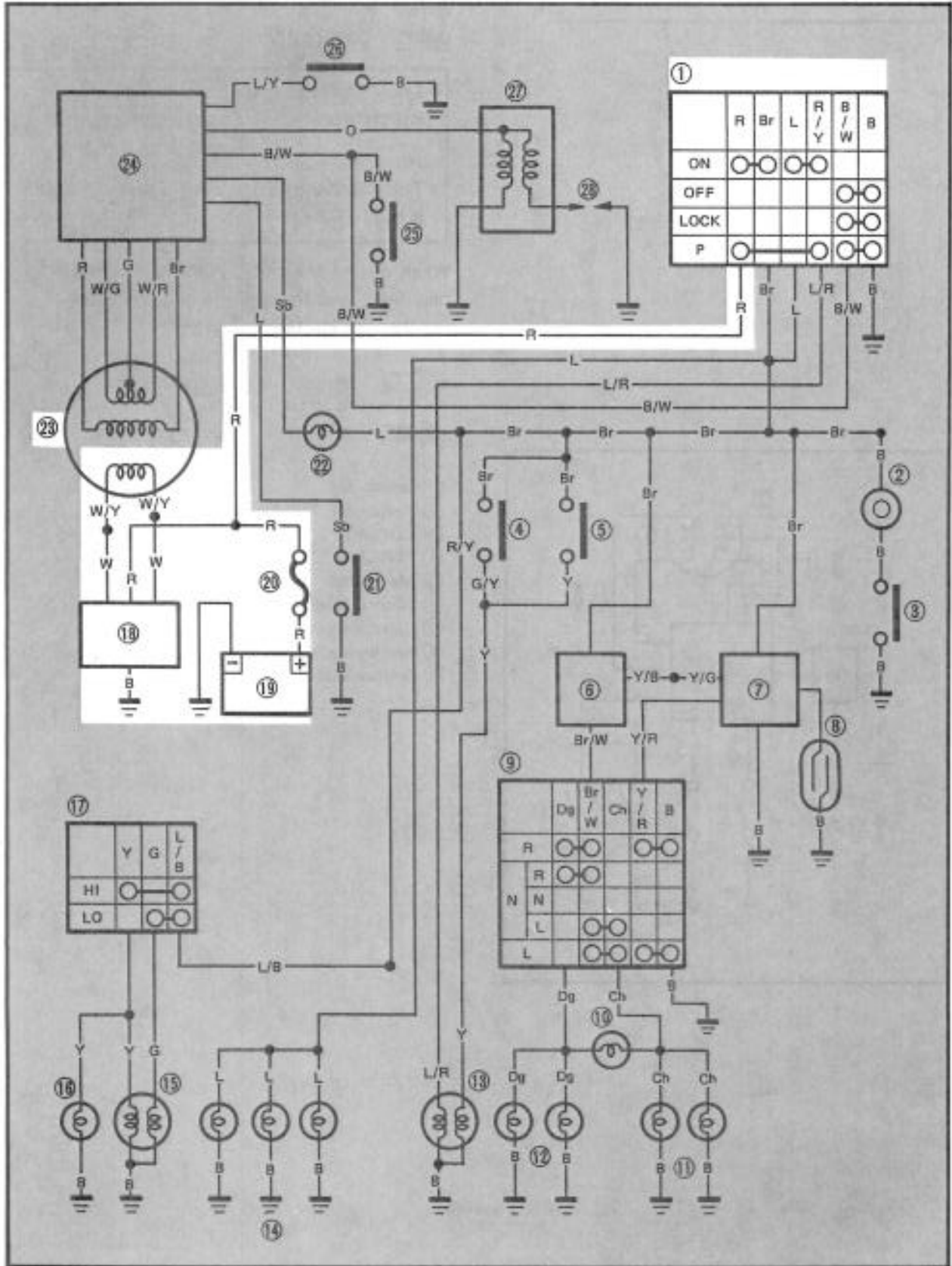



Aforementioned circuit diagram shows charging circuit in wiring diagram.

**NOTE:**

For the encircled numbers and color codes, see page 6-2.

- ① Main switch
- ⑱ Rectifier/Regulator
- ⑲ Battery
- ⑳ Circuit breaker
- ㉓ CDI magneto

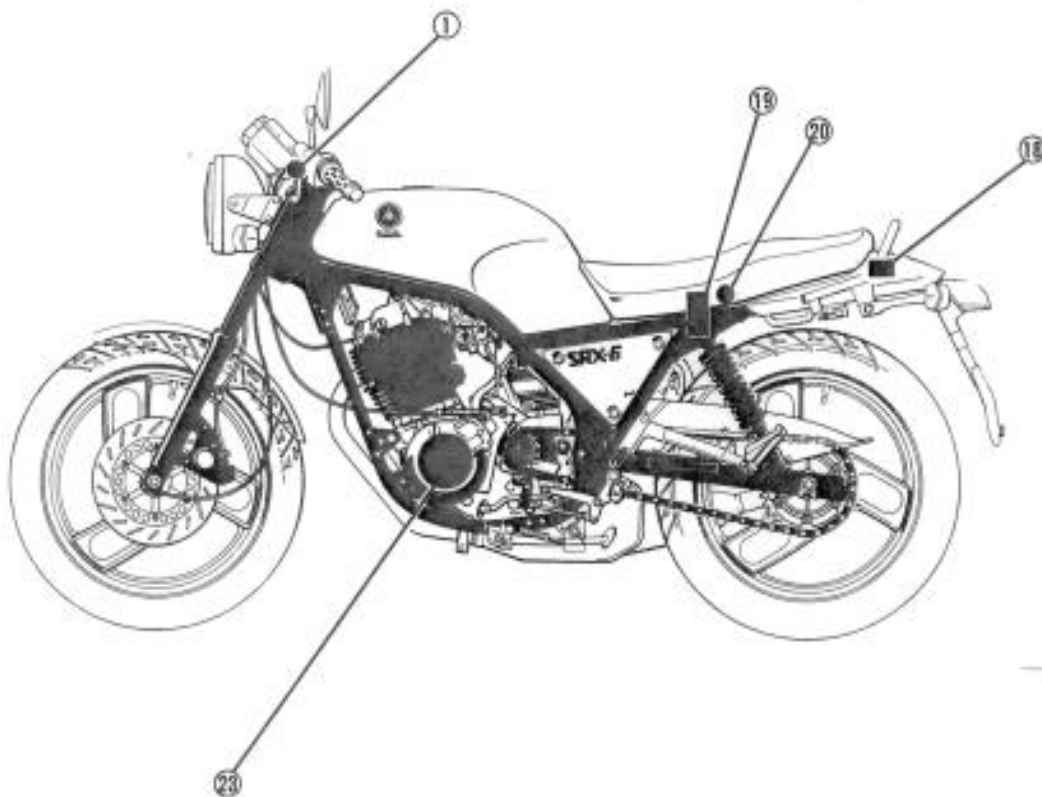



## TROUBLESHOOTING

## NOTE:

Before this troubleshooting, remove the side covers and seat.

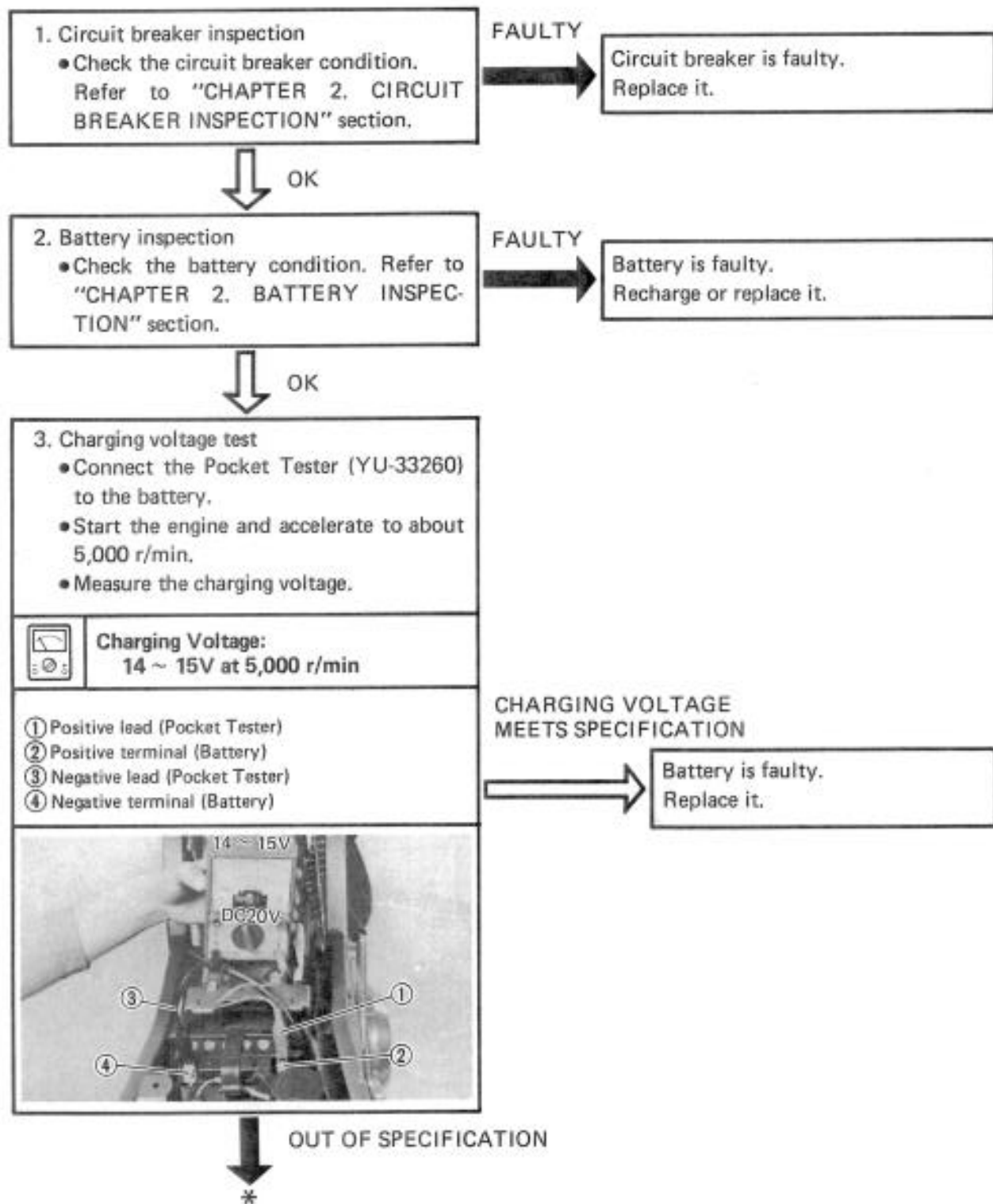





#### 4. Charging coil resistance test

- Disconnect the CDI magneto leads (White/Yellow ① and White/Yellow ②) from the wire harness.
- Connect the Pocket Tester (YU-33260) to the CDI magneto leads.
- Measure the charging coil resistance.



**Charging Coil Resistance**  
(White/Yellow ① –  
White/Yellow ②):  
0.2 ~ 0.6Ω at 20°C (68°F)

OUT OF  
SPECIFICATION

Charging coil is faulty.  
Replace stator assembly.

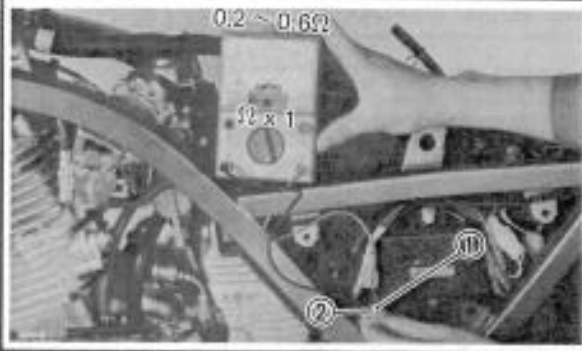

RESISTANCE MEETS SPECIFICATION

#### 5. Check entire charging system for connections.

- Refer to "WIRING DIAGRAM" section.

POOR  
CONNECTION

Correct.



OK

Rectifier/Regulator is faulty. Replace it.

**LIGHTING SYSTEM**

**CIRCUIT DIAGRAM**

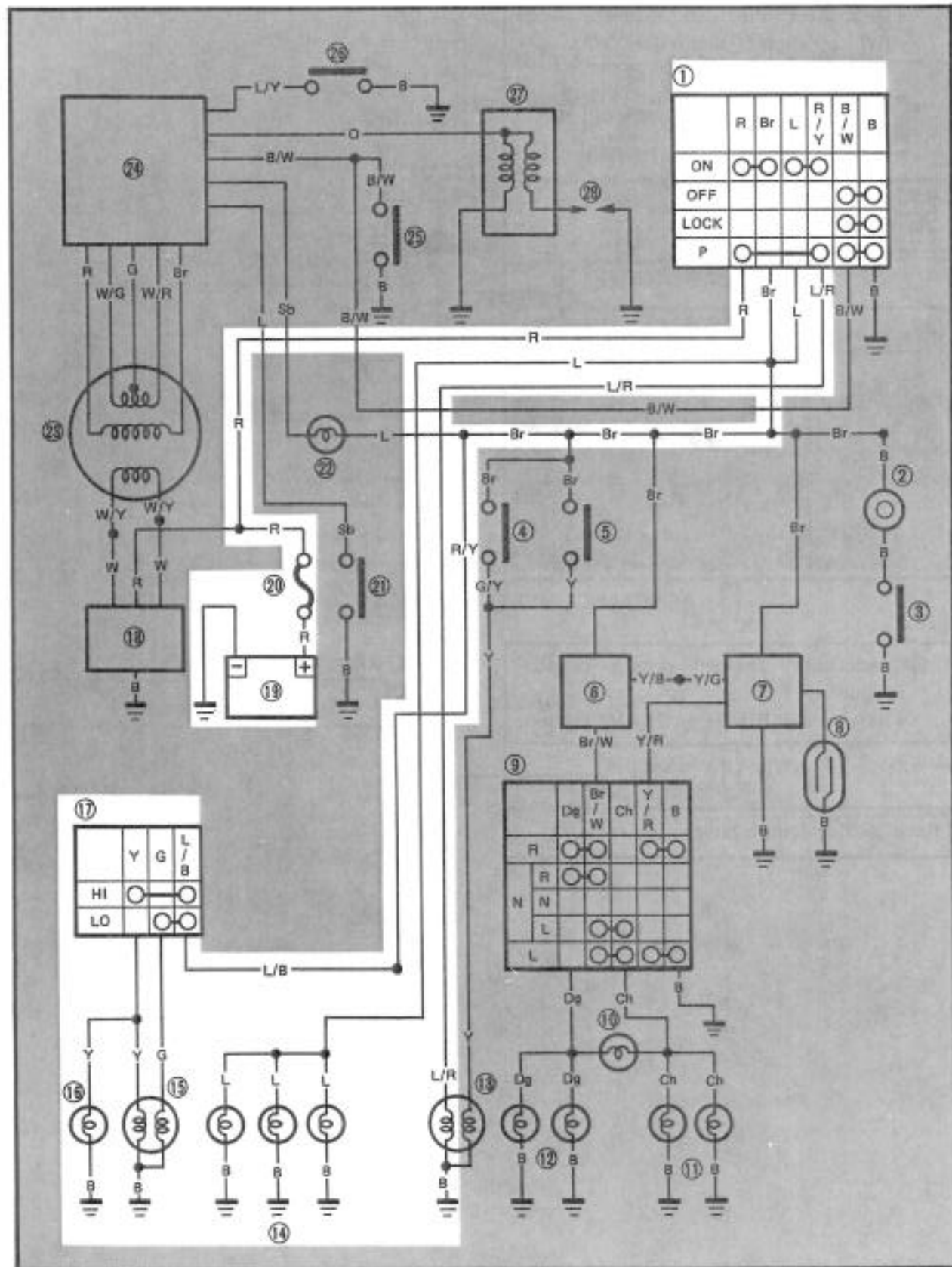



Aforementioned circuit diagram shows lighting circuit in wiring diagram.

**NOTE:**

For the encircled numbers and color codes, see page 6-2.

- ① Main switch
- ⑬ Tail/Brake light
- ⑭ Meter light
- ⑮ Headlight
- ⑯ "HIGH BEAM" indicator light
- ⑰ "LIGHTS" (Dimmer) switch
- ⑲ Battery
- ⑳ Circuit breaker

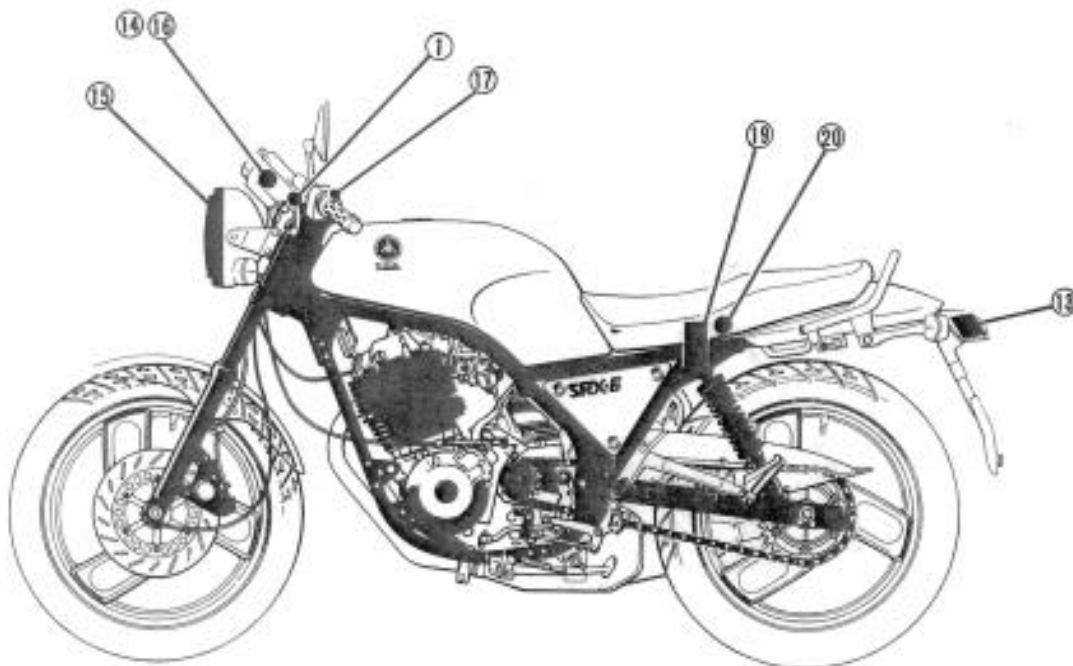



## TROUBLESHOOTING

## NOTE:

Before this troubleshooting, remove the side covers and seat.

## HEADLIGHT DOES NOT COME ON.

## 1. Headlight bulb conduct check

- Remove the headlight bulb ①. Refer to "CHAPTER 2. HEADLIGHT BULB REPLACEMENT" section.
- Connect the Pocket Tester (YU-33260) to the bulb terminals as shown, and check the bulb for continuity.

CONTINUITY DOES NOT  
EXIST ON CIRCUIT

Bulb is faulty.  
Replace it.

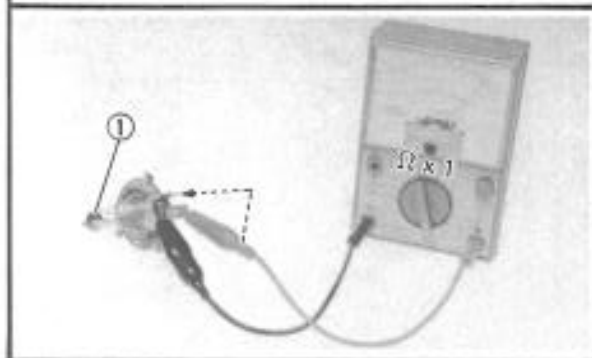

CONTINUITY EXISTS ON  
BOTH CIRCUIT

## 2. Headlight bulb socket conduct check

- Install the bulb to the headlight socket.
- Connect the Pocket Tester (YU-33260) to the headlight leads (Black ①, Yellow ② and Green ③), and check it for continuity.

CONTINUITY DOES NOT  
EXIST ON CIRCUIT

Bulb socket is faulty.  
Replace it.

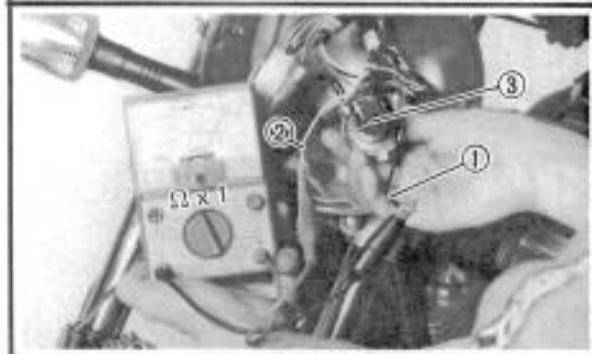

CONTINUITY EXISTS ON  
BOTH CIRCUIT

## 3. Circuit breaker inspection

- Check the circuit breaker condition. Refer to "CHAPTER 2. CIRCUIT BREAKER INSPECTION" section.

FAULTY

Circuit breaker is faulty.  
Replace it.

OK  
\*



4. Battery inspection

- Check the battery condition. Refer to "CHAPTER 2. BATTERY INSPECTION" section.

FAULTY

Battery is faulty.  
Recharge or replace it.



5. Lighting voltage test

- Connect the Pocket Tester (YU-33260) to the headlight leads (Black ①, Yellow ② and Green ③).
- Turn the "LIGHTS" (Dimmer) switch to "LO" position.
- Start the engine and accelerate to about 5,000 r/min.
- Measure the lighting voltage.

LIGHTING VOLTAGE  
MEETS SPECIFICATION

Lighting system (Headlight) is good.



Lighting Voltage:  
14 ~ 15V at 5,000 r/min

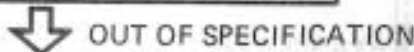
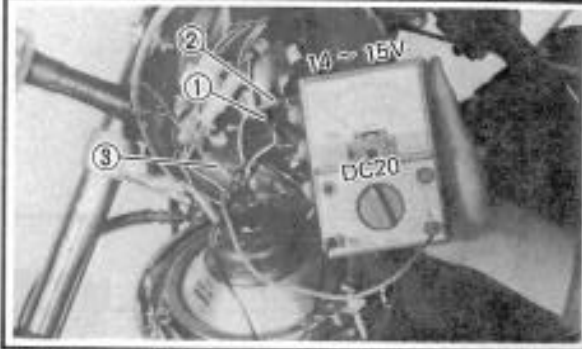

6. "LIGHTS" (Dimmer) switch conduct check.

- Check the "LIGHTS" (Dimmer) switch for continuity. Refer to "SIGNAL SYSTEM" section.

FAULTY

"LIGHTS" (Dimmer) switch is faulty.  
Replace faulty part(s).



7. Main switch conduct check

- Check the main switch for continuity. Refer to "SIGNAL SYSTEM" section.

FAULTY

Main switch is faulty.  
Replace it.

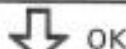

8. Check entire lighting system for connections.

- Refer to "WIRING DIAGRAM" section.

POOR CONNECTION

Correct.

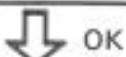

Check the charging system.

**TAILLIGHT DOES NOT COME ON.**
**1. Taillight bulb conduct check**

- Remove the taillight lens and bulb ①.
- Connect the Pocket Tester (YU-33260) to the bulb terminals as shown, and check the bulb for continuity.

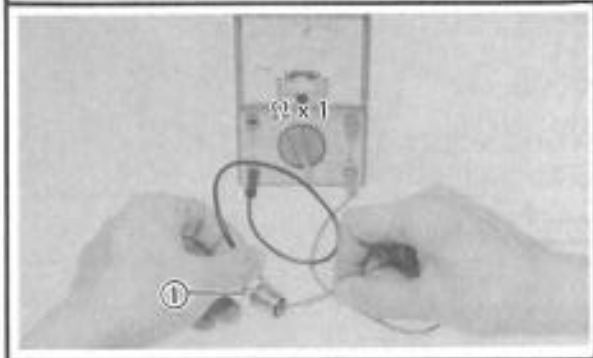
**NO CONTINUITY**
**Bulb is faulty.  
Replace it.**

**CONTINUITY**
**2. Taillight bulb socket conduct check**

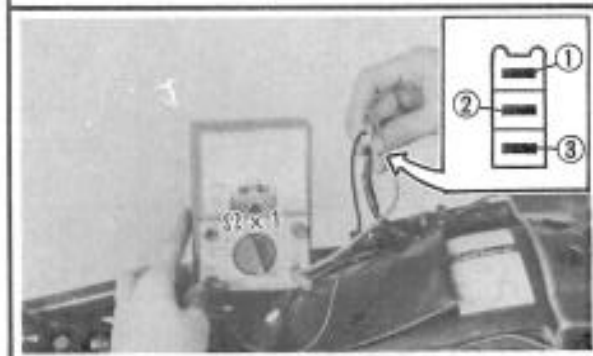
- Install the bulb to taillight socket.
- Disconnect the taillight leads (Blue ①, Black ② and Yellow ③).
- Connect the Pocket Tester (YU-33260) to the taillight leads as shown, and check it for continuity.

**CONTINUITY DOES NOT  
EXIST ON CIRCUIT**
**Bulb socket is faulty.  
Replace it.**

**CONTINUITY EXISTS ON  
BOTH CIRCUIT**
**3. Circuit breaker inspection**

- Check the circuit breaker condition.  
Refer to "CHAPTER 2. CIRCUIT  
BREAKER INSPECTION" section.

**FAULTY**
**Circuit breaker is faulty.  
Replace it.**

**OK**
**\***



4. Battery inspection  
 • Check the battery condition. Refer to "CHAPTER 2. BATTERY INSPECTION" section.

FAULTY

Battery is faulty.  
 Recharge or replace battery.



5. Lighting voltage test  
 • Connect the Pocket Tester (YU-33260) to the taillight leads (Blue ①, Black ② and Yellow ③).  
 • Start the engine and accelerate to about 5,000 r/min.  
 • Measure the lighting voltage.

LIGHTING VOLTAGE MEETS SPECIFICATION

Lighting system (Taillight) is good.



Lighting Voltage:  
 14 ~ 15V at 5,000 r/min

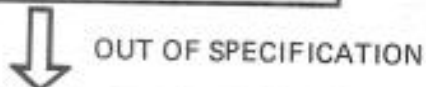
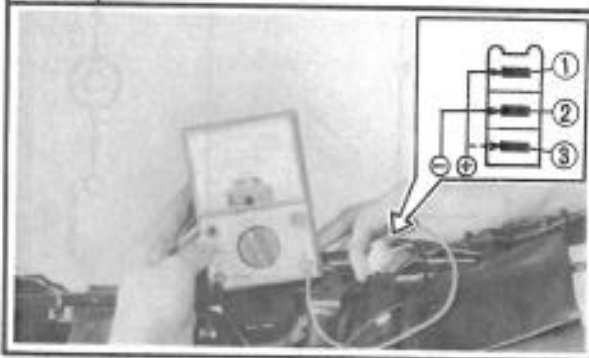

6. Main switch conduct check  
 • Check the main switch for continuity. Refer to "SIGNAL SYSTEM" section.

FAULTY

Main switch is faulty.  
 Replace it.

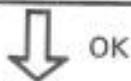

7. Check entire lighting system for connections.  
 • Refer to "WIRING DIAGRAM" section.

POOR CONNECTION

Correct.



Check the charging system.



**SIGNAL SYSTEM  
CIRCUIT DIAGRAM**

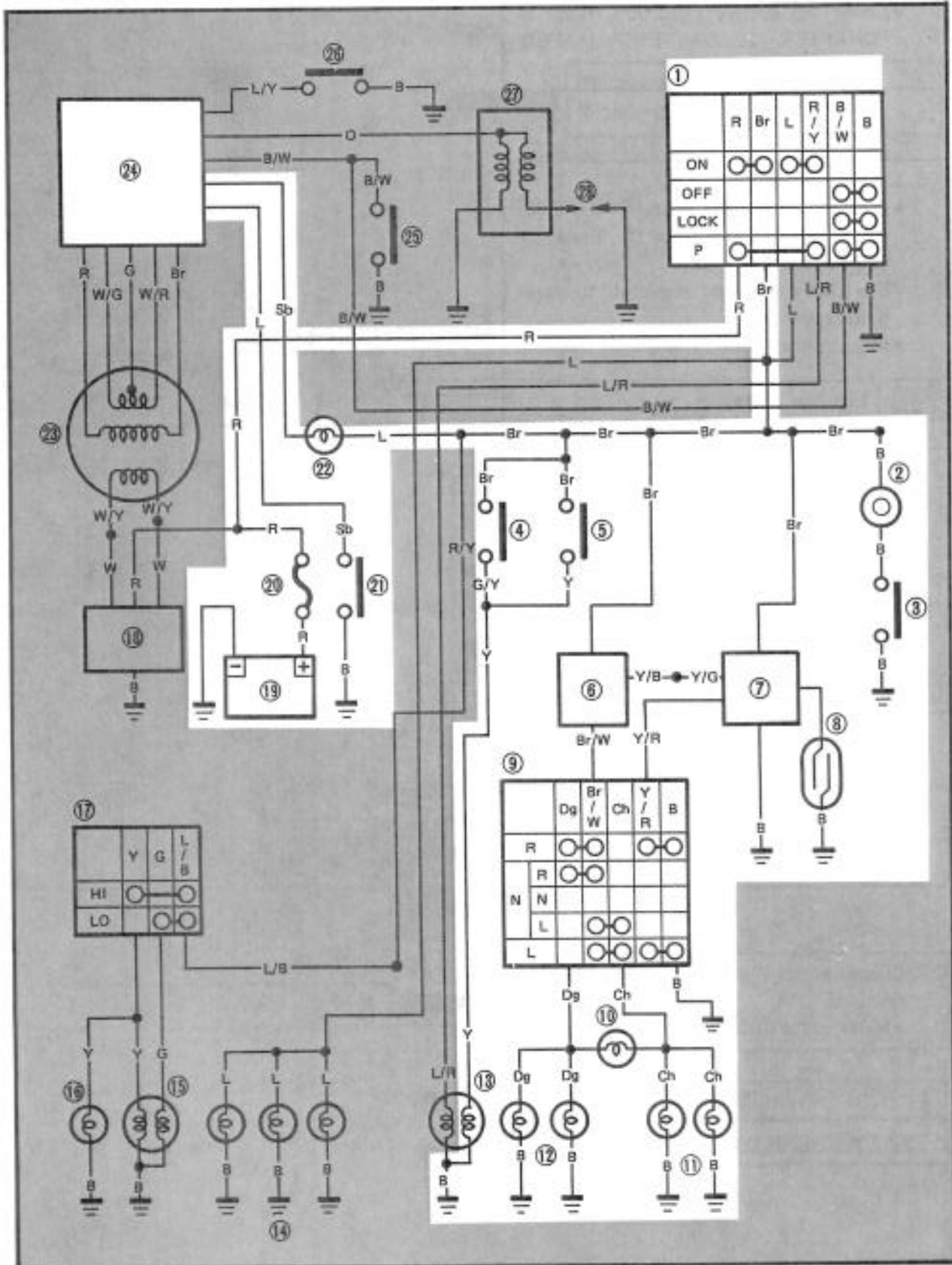





Aforementioned circuit diagram shows signal circuit in wiring diagram.

**NOTE:**

For the encircled numbers and color codes, see page 6-4.

- ① Main switch
- ② Horn
- ③ "HORN" switch
- ④ Front brake switch
- ⑤ Rear brake switch
- ⑥ Flasher relay
- ⑦ Cancelling unit
- ⑧ Reed switch
- ⑨ "TURN" switch
- ⑩ "TURN" indicator light
- ⑪ Flasher light (Left)
- ⑫ Flasher light (Right)
- ⑬ Tail/Brake light
- ⑭ Battery
- ⑮ Circuit breaker
- ⑯ Neutral switch
- ⑰ "NEUTRAL" indicator light
- ⑱ CDI unit

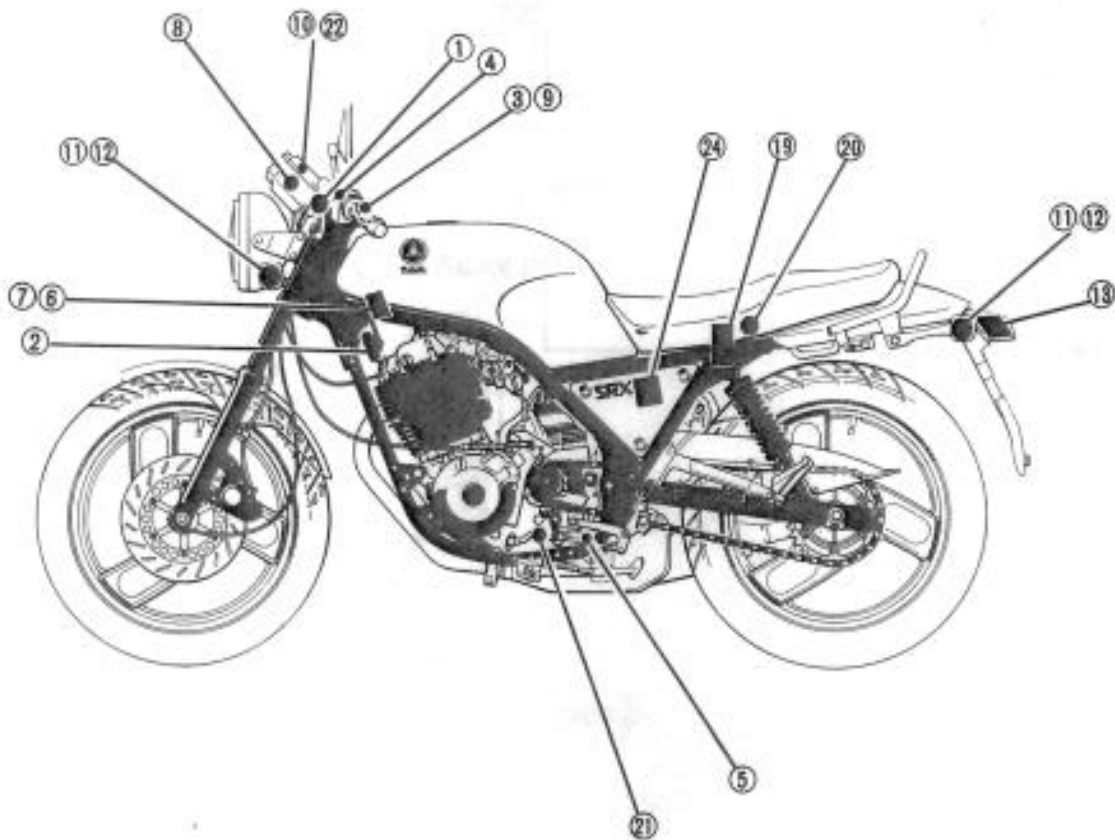



## TROUBLESHOOTING

## NOTE:

Before this troubleshooting, remove the side covers, seat and fuel tank.

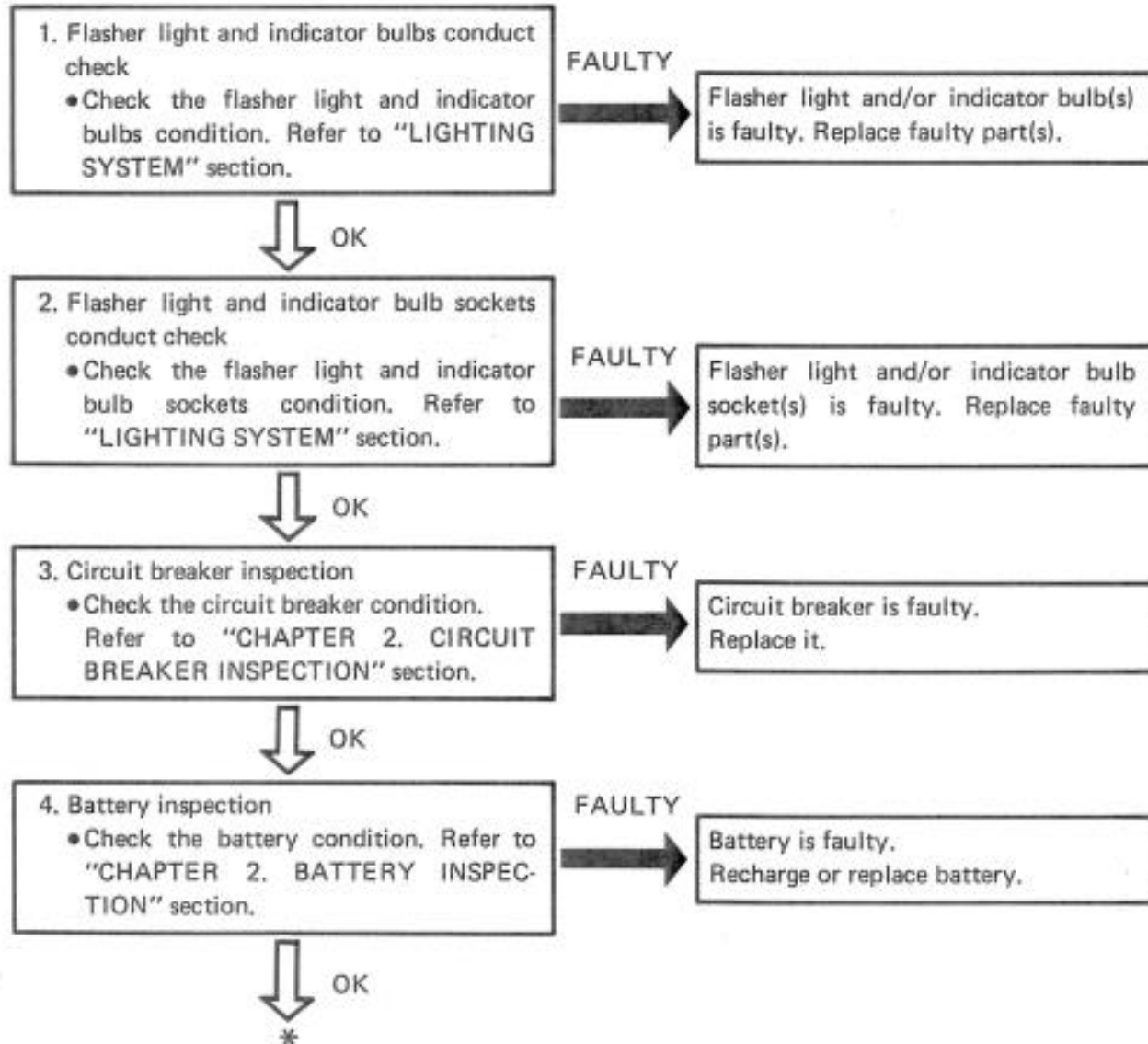
**THE FLASHER LIGHT AND INDICATOR LIGHT DO NOT COME ON.**



### 5. Battery voltage test

- Disconnect the flasher relay coupler.
- Connect the positive lead ① of the Pocket Tester (YU-33260) to the flasher relay lead (Brown ② – Wire harness side).
- Ground the negative lead ③ of the Pocket Tester to the frame.
- Turn the main switch to "ON", and measure the battery voltage.

LESS THAN 12V

Check main switch.

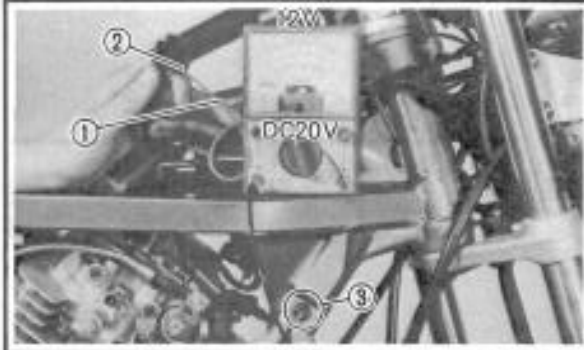

MORE THAN 12V

### 6. Flasher relay test

- Connect the flasher relay coupler terminals (Brown ① and Brown/White ②) with the jumper lead ③.
- Turn the main switch to "ON", and turn the "TURN" switch to "L" or "R".
- Check the flasher light condition.

DOES NOT LIGHT

Check "TURN" switch.

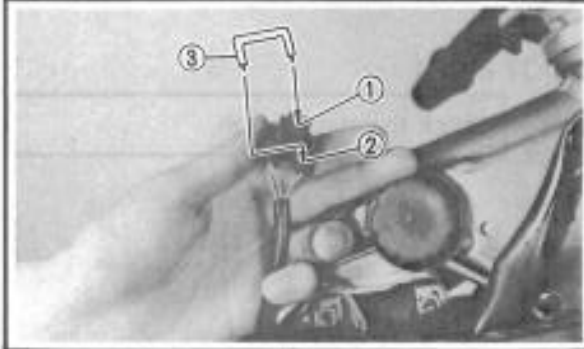

OK

### 7. Check entire signal system for connections.

- Refer to "WIRING DIAGRAM" section.

FAULTY

Correct.



LIGHTS

Replace flasher relay.

**THE BRAKE LIGHT DOES NOT COME ON.**

1. Brake light bulb conduct check
- Remove the taillight lens and bulb.
  - Check the brake light bulb condition. Refer to "LIGHTING SYSTEM" section.

**FAULTY**

 Brake light bulb is faulty.  
Replace it.

2. Brake light bulb socket conduct check
- Check the brake light bulb socket condition. Refer to "LIGHTING SYSTEM" section.

**FAULTY**

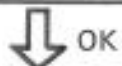
 Brake light bulb socket is faulty.  
Replace it.

3. Circuit breaker inspection
- Check the circuit breaker condition. Refer to "CHAPTER 2. CIRCUIT BREAKER INSPECTION" section.

**FAULTY**

 Circuit breaker is faulty.  
Replace it.

4. Battery inspection
- Check the battery condition. Refer to "CHAPTER 2. BATTERY INSPECTION" section.

**FAULTY**

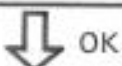
 Battery is faulty.  
Recharge or replace battery.

5. Front and rear brake switches test
- Disconnect the front and rear brake switch couplers.
  - Connect the front brake switch terminals (Brown ① and Green/Yellow ②) and rear brake switch terminals (Brown ③ and Yellow ④) with the jumper leads ⑤.
  - Turn the main switch to "ON", and check the brake light condition.

**DOES NOT LIGHT**

Check the main switch.

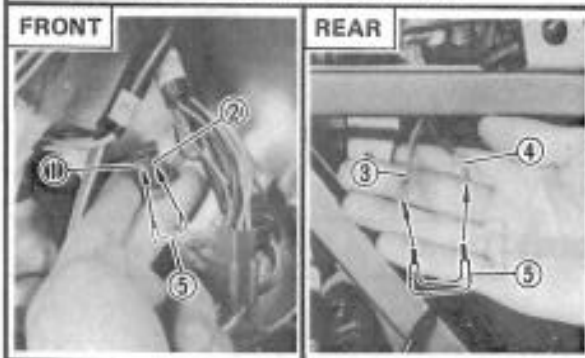



6. Check entire signal system for connections.

FAULTY

Correct.



Replace front and/or rear brake switch(es).



THE "NEUTRAL" INDICATOR LIGHT DOES NOT COME ON.

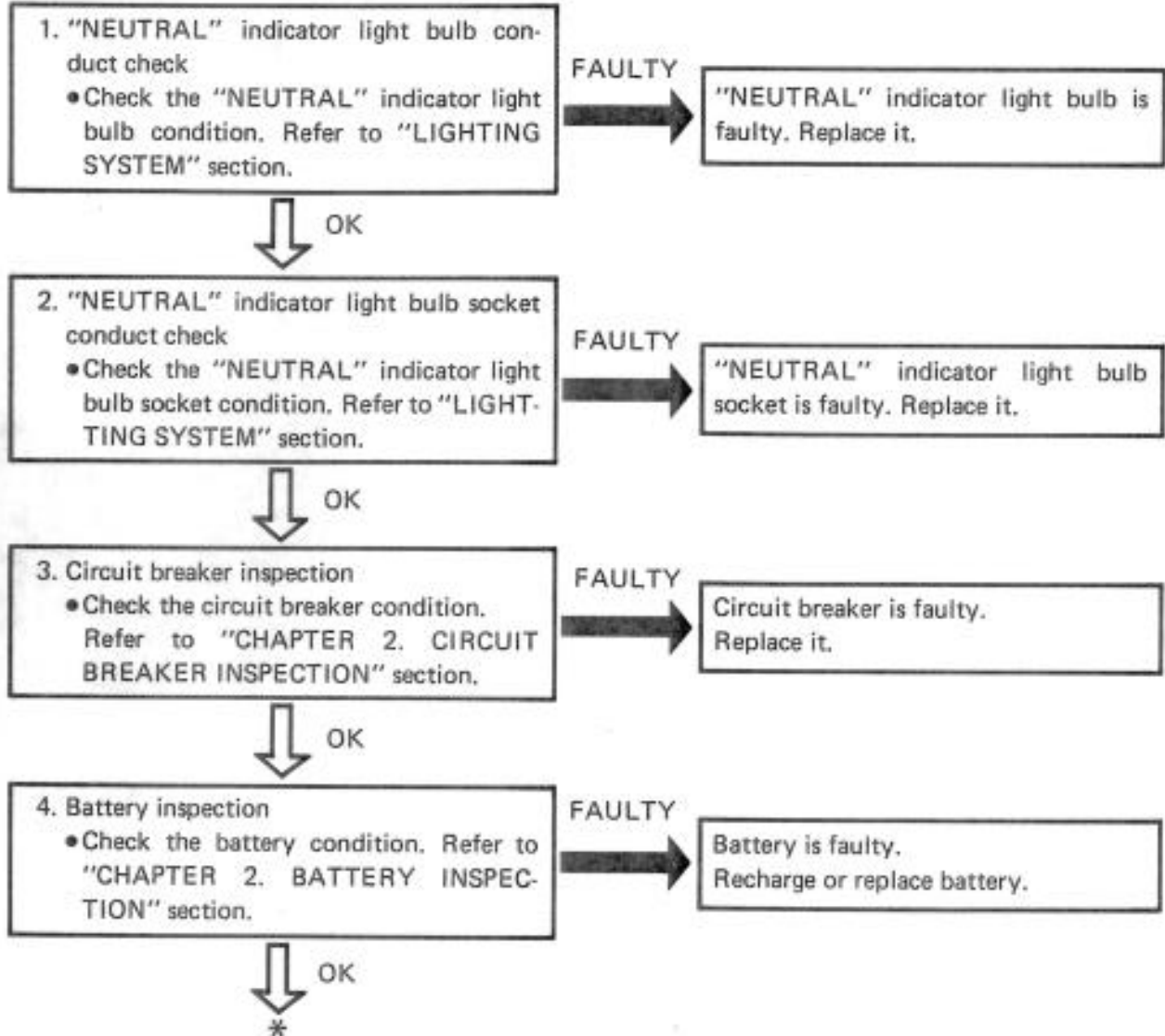



5. Battery voltage test

- Disconnect the neutral switch lead (Blue ① – Wire harness side).
- Connect the positive lead ② of the Pocket Tester (YU-33260) to the neutral switch lead.
- Ground the negative lead ③ of the Pocket Tester to the engine.
- Turn the main switch to "ON", and measure the battery voltage.

LESS THAN 12V

Check main switch.

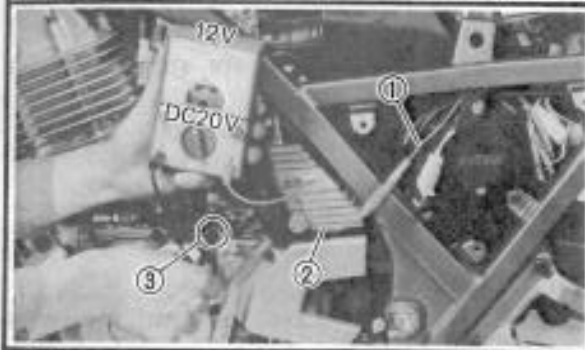

MORE THAN 12V

6. Neutral switch test

- Ground the neutral switch lead (Blue ① – Wire harness side) to the engine with the jumper lead ②.
- Shift the gear in neutral.
- Turn the main switch to "ON", and check the "NEUTRAL" indicator light condition.

LIGHTS

Neutral switch is faulty.  
Replace it.

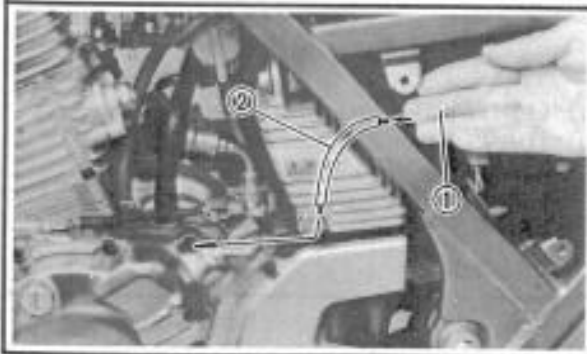

DOES NOT LIGHT

7. Check entire signal system for connection.
- Refer to "WIRING DIAGRAM" section.

FAULTY

Correct.



**SELF-CANCELLING FLASHER SYSTEM  
(Except for Germany)**

**Description**

The self-cancelling flasher system turns off the turn signal after a period of time or distance involved in turning or changing lanes. Generally, the signal will cancel after either 10 seconds, or 150 meters (490 feet), whichever is greater. At very low speed, the function is determined by distance; at high speed, especially when changing speeds, the cancelling determination is a combination of both times and distance. The self-cancelling mechanism only operates when the motorcycle is moving; thus the signal will not self-cancel while you are stopped at an intersection.

① Flasher relay

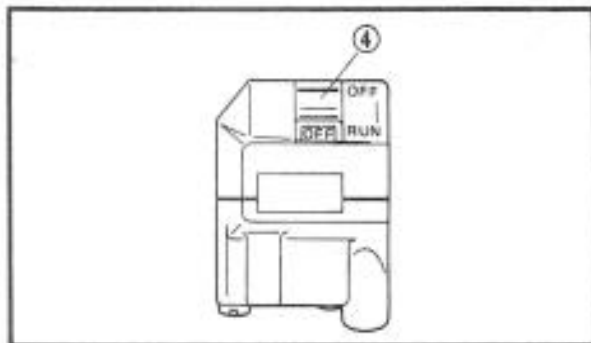
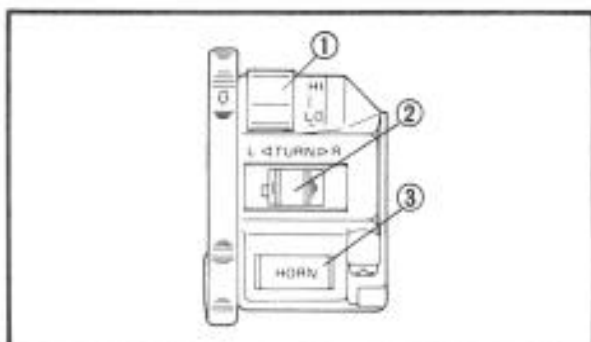

**SWITCHES TEST**

Switches may be checked for continuity with the Pocket Tester (YU-33260) on the "Ohm x 1" position.

- ① "LIGHTS" (Dimmer) switch
- ② "TURN" switch
- ③ "HORN" switch
- ④ "ENGINE STOP" switch

**Main Switch**

Switch Position	Lead Color					
	R	Br	L	R/Y	B/W	B
ON	○—○		○—○			
OFF					○—○	
LOCK					○—○	
P	○—○			○—○	○—○	



**"LIGHTS" (Dimmer) Switch**

Switch Position	Lead Color		
	Y	G	L/B
HI	○	○	○
LO		○	○

**"TURN" Switch**

Switch Position	Lead Color				
	Dg	Br/W	Ch	Y/R	B
R	○	○		○	○
N	R	○	○		
	N				
	L		○	○	
L		○	○	○	○

**"HORN" Switch**

Switch Position	Lead Color	
	P	B
OFF		
ON	○	○

**"ENGINE STOP" Switch**

Switch Position	Lead Color	
	B	B/W
OFF	○	○
RUN		